

## Lecture 1

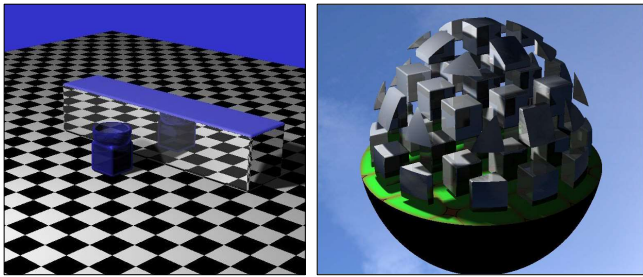

Ray Marching and Signed Distance Fields

Alex Benton, University of Cambridge – alex@bentonian.com  
Supported in part by Google UK, Ltd

1

## GPU Ray-tracing

Ray tracing 101: “Choose the color of the pixel by firing a ray through and seeing what it hits.”

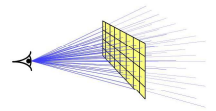

Ray tracing 102: “Let the pixel make up its own mind.”

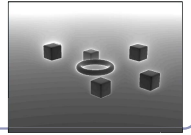
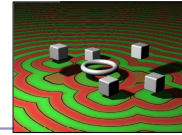
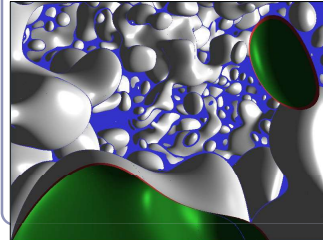

2

## GPU Ray-tracing

1. Set up OpenGL with minimal geometry, a single quad, flat to the quad
2. Vertex shader: minimal (no transforms, just pass through)
3. Fragment shader:
  - a. Compute the ray from the eye through the pixel
  - b. Intersect ray against scene
  - c. Shade pixel to color of hit object, with illumination, reflections, transparency...

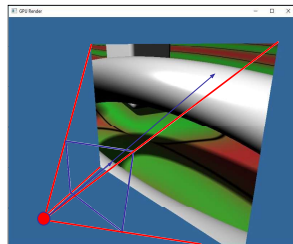

```
// Find ray from camera through pixel
// (Camera screen depth set to 5)
vec3 getRayDir(vec3 camDir, vec3 camUp, vec2 pixel) {
    vec3 xAxis = normalize(cross(camDir, camUp));
    vec2 p = 2.0 * pixel - 1.0;
    return normalize(p.x * xAxis + p.y * camUp + 5 * camDir);
}
```

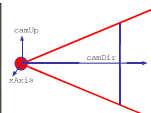

3

## Ray-marching

An alternative to classic ray-tracing is *ray-marching*, in which we take a series of finite steps along the ray until we strike an object or exceed the number of permitted steps.

- Scene objects only need to answer, “has this ray hit you? y/n”
- Great solution for data like height fields
- Caution:
  - Too large a step size can lead to lost intersections (step over the object)
  - Too small a step size can lead to GPU churn and wasted cycles

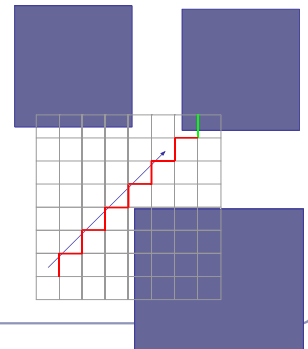

## GPU Ray-marching with Signed Distance Fields

Ray-marching can be dramatically improved, to impressive realtime GPU performance, using *signed distance fields*:

1. Fire ray into scene
2. At each step, measure distance field function:  $d(p)$  = [distance to nearest object in scene]
3. Advance ray along ray heading by distance  $d$ , because the nearest intersection can be no closer than  $d$

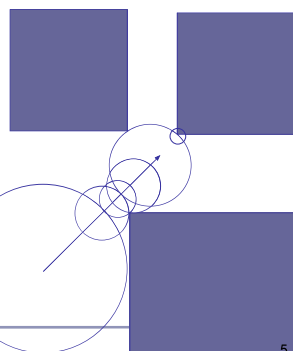

This is also sometimes called ‘sphere tracing’. Early paper: <http://graphics.cs.illinois.edu/sites/default/files/rtrats.pdf>

5

## Signed distance fields

An *SDF* returns the minimum possible distance from point  $p$  to the surface it describes.

The sphere, for instance, is the distance from  $p$  to the center of the sphere, minus the radius.

Negative values indicate a sample inside the surface, and still express absolute distance to the surface.

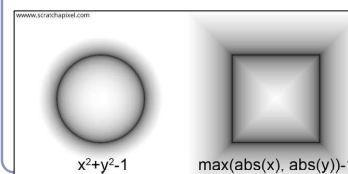

```
float sphere(vec3 p, float r) {
    return length(p) - r;
}

float cube(vec3 p, float r) {
    return max(max(abs(p.x),
                    abs(p.y)), abs(p.z)) - r;
}

float cylinderY(vec3 p, float r) {
    return length(p.xz) - r;
}

float torus(vec3 p, vec2 t) {
    vec2 q = vec2(
        length(p.xz) - t.x, p.y);
    return length(q) - t.y;
}
```

<https://www.scratchapixel.com/lessons/advanced-rendering/rendering-distance-fields/>

6

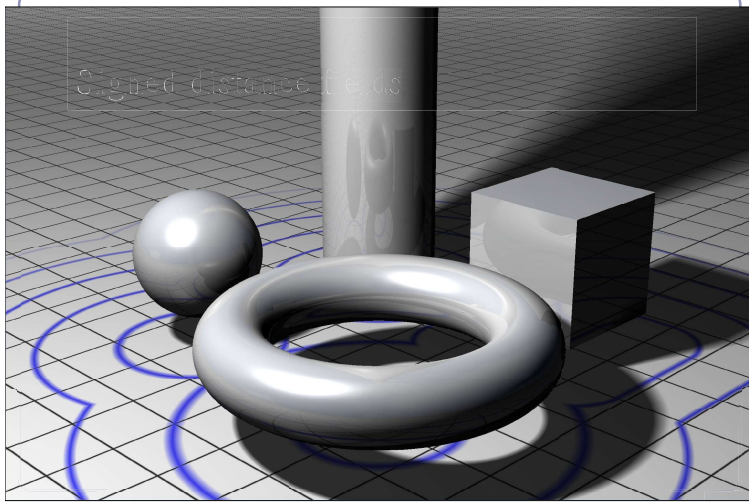

7

## The signed distance fields raymarching algorithm in glsl

```
vec3 raymarch(vec3 pos, vec3 raydir) {
    int step = 0;
    float d = getSdf(pos);

    while (abs(d) > 0.001 && step < 50) { // Step limit
        pos = pos + raydir * d;
        d = getSdf(pos); // Return e.g. sphere(pos)
        step++;
    }

    return
        (step < MAX) ? illuminate(pos, rayorig) : background;
}
```

8

## Visualizing step count

Final image

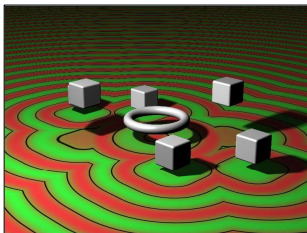

Distance field

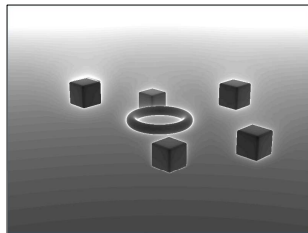

9

## Transforming SDF geometry

To rotate, translate or scale an SDF model, apply the inverse transform to the input point within your distance function.

```
float sphere(vec3 pt, float radius) {
    return length(pt) - radius;
}

float f(vec3 pt) {
    return sphere(pt - vec3(0, sin(time),
0));
}
```

Ex: adding  $(1, -2, 3)$  renders a sphere centered at  $(-1, 2, -3)$ .

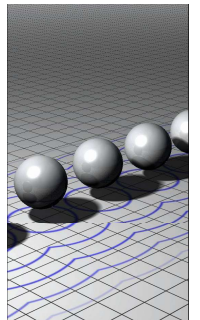

10

## Transforming SDF geometry

```
float fScene(vec3 pt) {
    // Scale 2x along X
    mat4 S = mat4(
        vec4(2, 0, 0, 0),
        vec4(0, 1, 0, 0),
        vec4(0, 0, 1, 0),
        vec4(0, 0, 0, 1));

    // Rotation in XY
    float t = sin(time) * PI / 4;
    mat4 R = mat4(
        vec4(cos(t), sin(t), 0, 0),
        vec4(-sin(t), cos(t), 0, 0),
        vec4(0, 0, 1, 0),
        vec4(0, 0, 0, 1));

    // Translate to (3, 3, 3)
    mat4 T = mat4(
        vec4(1, 0, 0, 3),
        vec4(0, 1, 0, 3),
        vec4(0, 0, 1, 3),
        vec4(0, 0, 0, 1));

    pt = (vec4(pt, 1) * inverse(S * R * T)).xyz;
    return sdSphere(pt, 1);
}
```

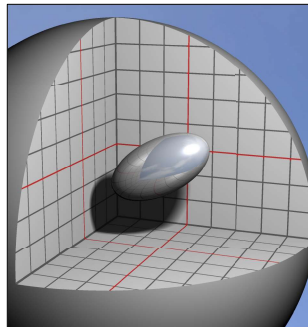

11

## Find the normal to an SDF

Finding the normal: local gradient

```
float d = getSdf(pt);
vec3 normal = normalize(vec3(
    getSdf(vec3(pt.x + 0.0001, pt.y, pt.z)) - d,
    getSdf(vec3(pt.x, pt.y + 0.0001, pt.z)) - d,
    getSdf(vec3(pt.x, pt.y, pt.z + 0.0001)) - d));
```

The distance function is locally linear and changes most as the sample moves directly away from the surface. At the surface, the direction of greatest change is therefore equivalent to the normal to the surface. Thus the local gradient (the normal) can be approximated from the distance function.

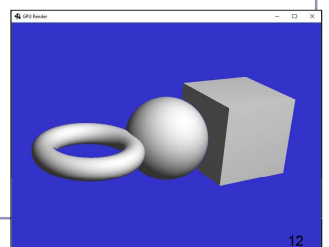

12

## SDF shadows

Ray-marched shadows are straightforward: march a ray towards each light source, don't illuminate if the SDF ever drops too close to zero.

Unlike ray-tracing, soft shadows are almost free with SDFs: attenuate illumination by a linear function of the ray marching *near* to another object.

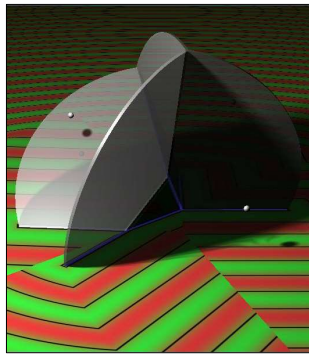
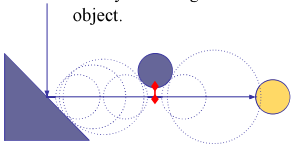

13

## Soft SDF shadows

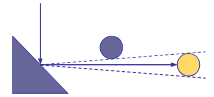

```
float shadow(vec3 pt) {
    vec3 lightDir = normalize(lightPos - pt);
    float kd = 1;
    int step = 0;

    for (float t = 0.1;
         t < length(lightPos - pt)
         && step < renderDepth && kd > 0.001; ) {
        float d = abs(getSDF(pt + t * lightDir));
        if (d < 0.001) {
            kd = 0;
        } else {
            kd = min(kd, 16 * d / t);
        }
        t += d;
        step++;
    }
    return kd;
}
```

By dividing  $d$  by  $t$ , we attenuate the strength of the shadow as its source is further from the illuminated point.

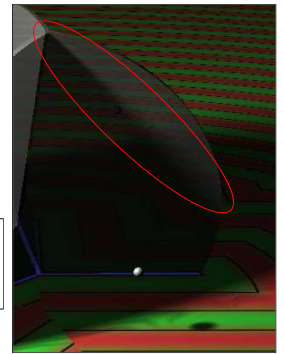

14

## Combining SDFs

We combine SDF models by choosing which is closer to the sampled point.

- Take the **union** of two SDFs by taking the `min()` of their functions.
- Take the **intersection** of two SDFs by taking the `max()` of their functions.
- The `max()` of function A and the negative of function B will return the **difference** of A - B.

By combining these binary operations we can create functions which describe very complex primitives.

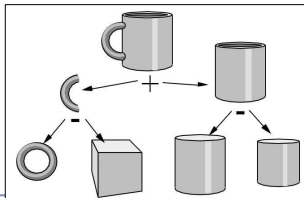
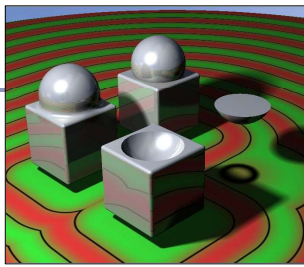

15

## Blending SDF geometry

Taking the `min()`, `max()`, etc of two SDFs yields a sharp discontinuity. *Interpolating* the two SDFs with a smooth polynomial yields a smooth distance curve, blending the models:

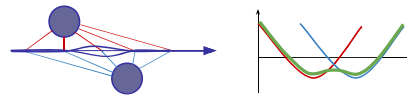

Sample blending function (Quilez)

```
float smin(float a, float b) {
    float k = 0.2;
    float h = clamp(0.5 + 0.5 * (b - a) / k, 0, 1);
    return mix(b, a, h) - k * h * (1 - h);
}
```

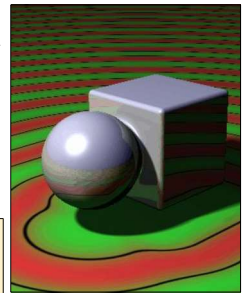

<http://iquilezles.org/www/articles/smin/smin.htm>

## Twists and deformations

We can apply non-uniform spatial distortion, such as by choosing how much we'll modify space as a function of where we are in space.

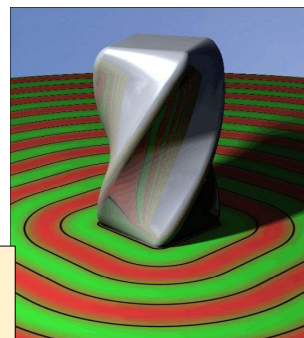

```
float fScene(vec3 pt) {
    pt.y -= 1;
    float t = (pt.y + 2.5) * sin(time);
    return sDCube(vec3(
        pt.x * cos(t) - pt.z * sin(t),
        pt.y / 2,
        pt.x * sin(t) + pt.z * cos(t)), vec3(1));
}
```

17

## Rounded corners

An SDF function returns distance to the surface, so if you subtract a constant, you round off hard edges and corners:

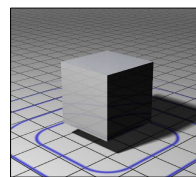

```
float cube(vec3 p) {
    vec3 d = abs(p) - vec3(1);
    return min(
        max(d.x, max(d.y, d.z)),
        0.0) + length(max(d, 0.0));
} // Exactly accurate cube SDF
```

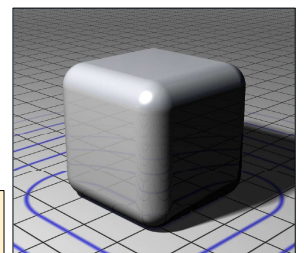

```
dist = cube(p) - 0.5;
```

18

## “Rounded corners” taken to extremes: Displacement maps

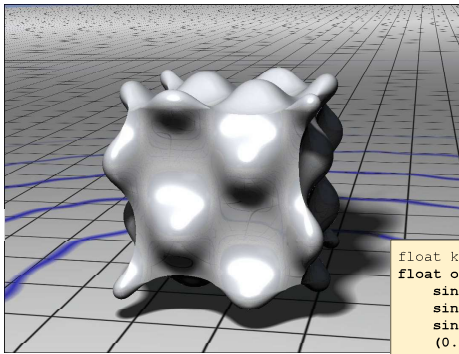

```
float k = 4;
float offset =
    sin(k * pt.x) *
    sin(k * pt.y) *
    sin(k * pt.z) *
    (0.25 + 0.25 * sin(time));
return cube(pt) + offset;
```

19

## Repeating SDF geometry

If we take the modulus of a point's position along one or more axes before computing its signed distance, then we segment space into infinite parallel regions of repeated distance. Space near the origin 'repeats'.

With SDFs we get infinite repetition of geometry for no extra cost.

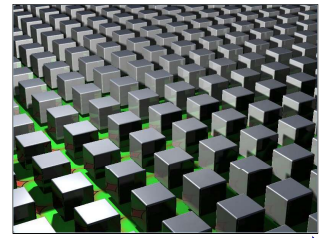

```
float fScene(vec3 pt) {
    vec3 pos;
    pos = vec3(mod(pt.x + 2, 4) - 2, pt.y, mod(pt.z + 2, 4) - 2);
    return sdCube(pos, vec3(1));
}
```

20

## SDF - Live demo

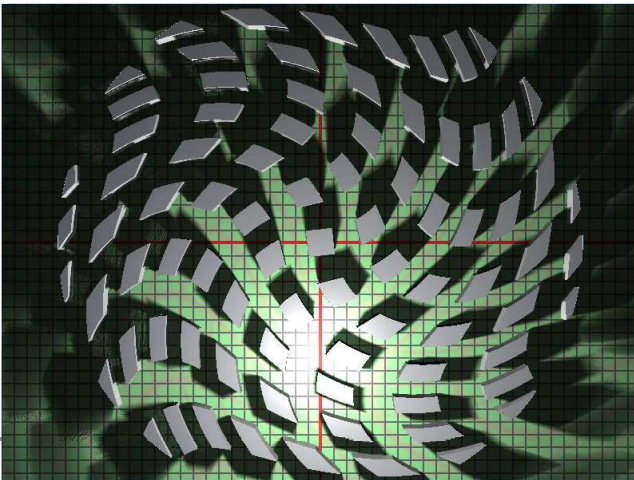

21

## Recommended reading

### Seminal papers

- John C. Hart, "Sphere Tracing: A Geometric Method for the Antialiased Ray Tracing of Implicit Surfaces", <http://graphics.cs.illinois.edu/papers/zero>
- John C. Hart et al., "Ray Tracing Deterministic 3-D Fractals", <http://graphics.cs.illinois.edu/sites/default/files/rtrqs.pdf>

### Special kudos to Inigo Quilez and his amazing blog

- <http://iquilezles.org/www/articles/smin/smin.htm>
- <http://iquilezles.org/www/articles/distfunctions/distfunctions.htm>

### Other useful sources

- Johann Korndorfer, "How to Create Content with Signed Distance Functions", <https://www.youtube.com/watch?v=s8nFqwOhos>
- Daniel Wright, "Dynamic Occlusion with Signed Distance Fields", <http://advances.realtimerendering.com/2015/DynamicOcclusionWithSignedDistanceFields.pdf>
- 9bit Science, "Raymarching Distance Fields", [http://9bitscience.blogspot.co.uk/2013/07/raymarching-distance-fields\\_14.html](http://9bitscience.blogspot.co.uk/2013/07/raymarching-distance-fields_14.html)

22

## Lecture 2

## Implicit Surfaces Particle Systems



Left: Inigo Quilez's *Particle Systems* (SIGGRAPH 2012) and all model built with MetalBryce's *MD*  
Right: *Particle Systems* (SIGGRAPH 2012) and all model built with MetalBryce's *MD*

Right: *Particle Systems* (SIGGRAPH 2012) and all model built with MetalBryce's *MD*

Alex Benton, University of Cambridge - alex@bentonian.org  
Supported in part by Google UK, Ltd

## Implicit surfaces

Signed Distance Fields are just one example of the broad class of *implicit surfaces*.

An implicit surface is any description of a set of points which satisfy the equation

$$F(\mathbf{P}) = 0$$

where  $\mathbf{P} \in \mathbb{R}^3$  for a 3D surface.

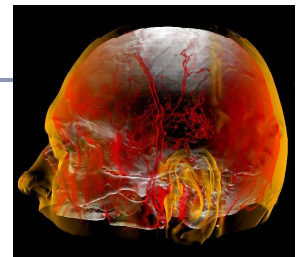

Image credit: Balazs Csobánc, Balazs Tóth, Stefan Brackner, Mester Ede and Gröller  
*Implicit Surfaces: A Geometric Method for the Antialiased Ray Tracing of Implicit Surfaces*  
*Proceedings of Vision, Modeling & Visualization 2012*, pages 105-109, November 2012.

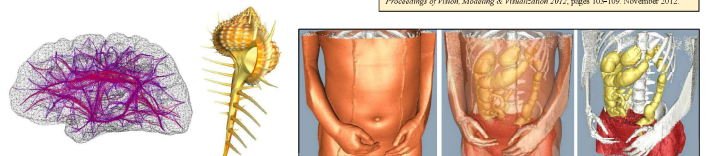

Image credit: W. Lorenzen, *Marching Through the Visible Man*, 1995

24

## Implicit surfaces in modern animation:

### Metaballs (sometimes called "metaball modeling", "force functions", "blobby modeling" ...)

Metaballs are an early (1980s) technique for creating smooth, blobby, organic surfaces.

Metaballs leverage the fact that if two functions  $F(P)=0$  and  $G(P)=0$  describe implicit surfaces, then  $F(P)+G(P)=0$  describes a surface blending both shapes.

Metaball models are described by a set of *control points*. Each control point  $p$  generates a 'field' of force, which drops off as a function  $F(r)$  where  $r$  is the scalar radius from the control point.

The implicit surface is the set of all points in space where the sum of these field equals a chosen constant:

$$S = \{x \in \mathbb{R}^3 \mid \sum_p F(|x-p|) = \tau\}$$

The surface thus solves the expression:

$$\sum_p F(|x-p|) - \tau = 0$$

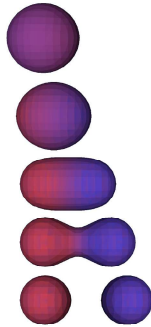

25

## Metaball modeling force functions

### Common force functions:

- "Blobby Molecules" – Jim Blinn

$$F(r) = a e^{-br^2}$$

- "Metaballs" – Jim Blinn

$$F(r) = \begin{cases} a(1 - 3r^2 / b^2) & 0 \leq r < b/3 \\ (3a/2)(1-r/b)^2 & b/3 \leq r < b \\ 0 & b \leq r \end{cases}$$

- "Soft Objects" – Wyvill & Wyvill

$$F(r) = a(1 - 4r^6/9b^6 + 17r^4/9b^4 - 22r^2 / 9b^2)$$

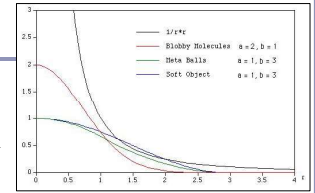

26

## Metaball modeling

Jim Blinn first used blobby models to animate electron orbital shells (1982).

Today animators and artists use blobby modeling to quickly create bumpy, organic surfaces.

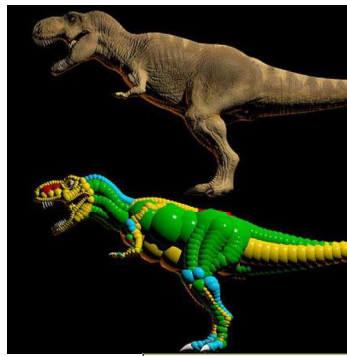

Jose Maria de Espoz, REM INFOGRAFICA, 1997

27

## Polygonizing implicit surfaces: Marching Cubes

The *Marching cubes* algorithm (Lorenson & Cline, 1985) finds a set of polygons approximating a surface:

1. Fire a ray from any point known to be inside the surface.
2. Using Newton's method or binary search, find one place where the ray crosses the surface.
3. Place a cube centered at the intersection point: some vertices will be "hot" (inside the surface), others "cold" (outside).
4. While there exists a cube which has at least one hot vertex and at least one cold vertex on a side and no neighboring cube sharing that face, create a neighboring cube at that face.

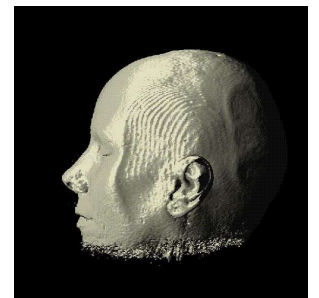

Marching cubes is common in medical imaging such as MRI scans. It was first demonstrated (and patented!) by researchers at GE in 1984, modeling a human spine.

28

## Cubes → Polygons

Each edge of the cube that has 1 hot and 1 cold corner, must be crossed by the isocline of the surface

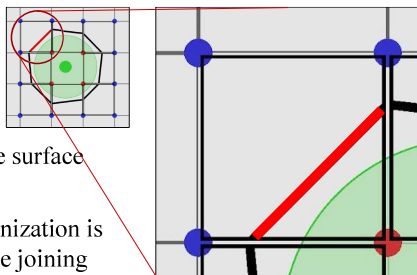

The simplest polygonization is to add a polygon face joining the midpoints of each crossed edge (but we can do better)

29

## Cubes → Polygons

```
int flags =
(isHot(T_L) ? 1 : 0) |
(isHot(T_R) ? 2 : 0) |
(isHot(B_R) ? 4 : 0) |
(isHot(B_L) ? 8 : 0);

switch (flags) {
case 1 :
// left side → top;
...
case 3 :
// left side → right;
...
case 10 :
// top → right side,
// AND,
// bottom → left side
...
}
```

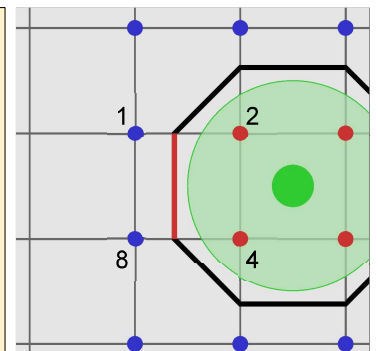

30

## Marching cubes squares in action

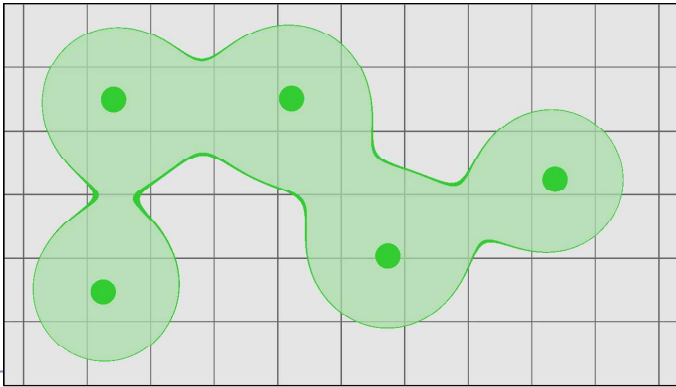

31

## Cubes → Polygons

In 3D, there are fifteen possible configurations (up to symmetry) of hot/cold vertices in the cube. →

- With rotations, that's 256 cases

Beware: there are *ambiguous cases* in the polygonization which must be addressed consistently. ↓

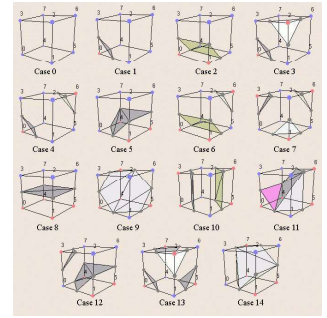
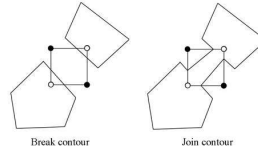

Images courtesy of [Diane Lingrand](#)

32

## Smoothing the polygonization

The simplest polygonization uses a polygon face joining the midpoints of each crossed edge  $P1 \rightarrow P2$ :

- $P = P1 + \frac{1}{2} (P2 - P1)$

The implicit surface can be more closely approximated by linearly interpolating along the edges of the cube by the weights of the relative values of the force function:

- $t = (0.5 - F(P1)) / (F(P2) - F(P1))$
- $P = P1 + t(P2 - P1)$

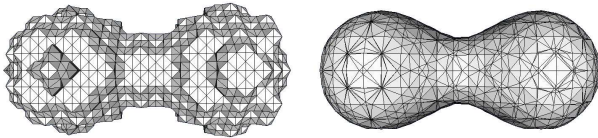

Same implicit surface

33

## Polygonizing implicit surfaces: Octrees

The *octree* is a recursive data structure which subdivides space to “home in” on an implicit surface. Each node of an octree is a cube, containing 0 or 8 child octrees.

- Each node of the tree occupies a cube in space
- Each node evaluates the force function  $F(v)$  at each of its vertices  $v$
- Recursive definition: subdivide the cube into 8 equal-sized children for every node where at least 1 corner vertex is inside the surface ('hot') and at least 1 is outside ('cold')



Image credit: J W Laprairie, Mark & Hamilton, Howard. (2018). *Isobox: A Brick-Octree Approach to Indirect Visualization*

34

## Progressive refinement: Octrees

To display a set of octrees, convert the octrees into polygons.

- If some corners are “hot” (inside the surface) and others are “cold” (outside) then the isosurface must cross the cube edges in between.
- The set of midpoints of adjacent crossed edges forms one or more rings, which can be triangulated. The normal is known from the inside/outside direction on the edges.

To refine the polygonization, subdivide recursively; discard any child whose vertices are all inside or all outside.

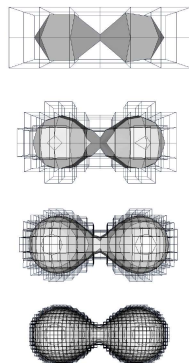

35

## Octree refinement in action

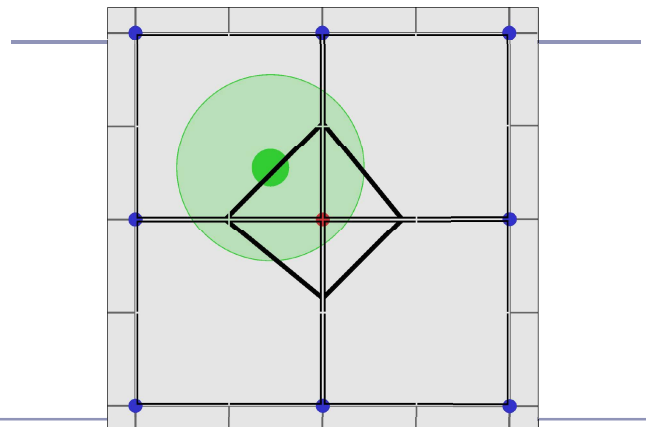

36

## Particle systems

Particle systems are a monte-carlo style technique which uses thousands (or millions) of tiny finite elements to create large-scale structural and visual effects.

Particle systems are used for hair, fire, cloth, smoke, water, spores, clouds, explosions, energy glows, in-game special effects and much more.

The basic ideas:

- “Very simple procedural rules can create very deep visual effects”
- “If lots of little dots all do something coherent, our brains will see the thing they do and not the dots doing it.”



Still from *Large Steps in Cloth Simulation*. David Baraff, Andrew P. Witkin. Published in SIGGRAPH 1998



Screenshot from the game *Command and Conquer 3* (2007) by Electronic Arts, the “lasers” are particle effects.

## Particle systems’ honorable history

1962: Ships explode into pixel clouds in “Spacewar!”, the 2<sup>nd</sup> video game ever.

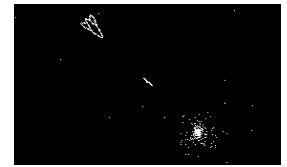

1978: Ships explode into broken lines in “Asteroid”



1982: The Genesis Effect in “Star Trek II: The Wrath of Khan”

Fanboy note: You can play the original *Spacewar!* at [spacewar.oversigma.com/](http://spacewar.oversigma.com/) -- the actual original game, running in a PDP-1 emulator inside a Java applet.

## Particle systems: Fluid simulation



“Position Based Fluids”, SIGGRAPH (2013) - Realtime fluid by Miles Macklin and Matthias Müller (NVIDIA) Supporting material for [Position Based Fluids](#), Miles Macklin, Matthias Müller, ACM TOG 32(4) (2013)

## Particle systems: Cloth simulation

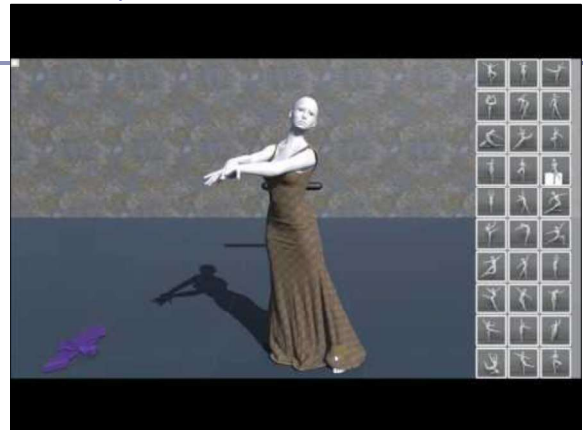

“Interactive Cloth Simulation”, Jim Hugunin - Realtime GPU-driven cloth in Unity game engine From his talk at Unite 2016, [GPU Accelerated High Resolution Cloth Simulation](#)

## Particle systems: Fracture simulation

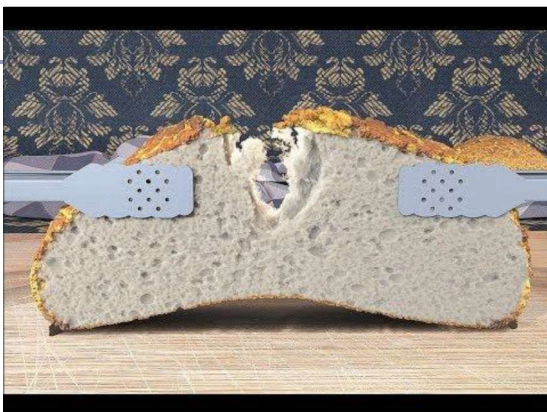

“CD-MPM: Continuum Damage Material Point Methods for Dynamic Fracture Animation” Video for SIGGRAPH 2019 for the paper *CD-MPM: Continuum Damage Material Point Methods for Dynamic Fracture Animation*, ACM Trans. Graph., Vol. 38, No. 4, Article 119. July 2019

## How does it work?

We want to ask,

- “A particle starts life with initial position and velocity. Given obstacles / forces / constraints, where will it wind up?”

or in other words...

- Solve this:
  - Given  $v = dX/dt = f(X(t), t)$
  - Given  $X(t_0) = X_0$
  - Find  $X(t)$  for  $t > t_0$

This is an ODE

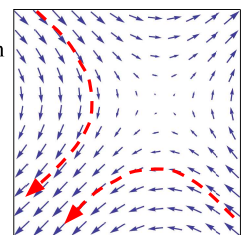

where  $X(t)$  is the particle position,  $dX/dt$  is the particle velocity,  $X_0$  is its initial position and  $f(X(t), t)$  is a (complicated? time- and position dependent?) equation that changes particle velocity

## Particle systems as Ordinary Differential Equations: Euler's Method

There are many ways to solve an ODE. The simplest (and most common in realtime graphics) is *Euler's Method*.

- “The forward difference method (Euler's Method) uses the rate values at the end of one timestep as though constant in the next timestep.” --[Numerical Methods](#)

This is effective, albeit error-prone

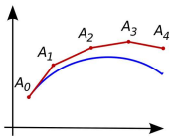

- ← Each step tangent to the path *could* take us further from the true path
- ← But we will still approximate the integral 'reasonably', for small enough steps
- ← Error can be bounded by short particle lifetimes, damping, and other practical tricks

Figure from [wikipedia](#)

43

## Example 1

A simple example--particles affected by gravity:

$$v(t) = v_0 + gt$$

(This has a known solution, because physics:  $X(t) = X_0 + v_0t + 1/2gt^2$ )

Approximated with Euler's method:

```
For each frame:
  For each particle:
    velocity = velocity
      + timestep * gravity
    position = position
      + timestep * velocity
```

This generalizes nicely to array-multiply and array-add operations which scale well on modern GPU hardware, allowing you to update velocity and position in a single GPU raster operation



Animation: <https://www.vsnorm.com/products/denise2/visualization/specialfx/>

44

## Example 2



A more complex example--particles affected by a position-dependent wind or force:

$$v(t) = v_0 + wind(x(t))$$

```
For each frame:
  For each particle:
    look up wind at position
    solve f=ma to find the
    acceleration of the wind on the
    mass of the particle
    velocity = velocity
      + timestep * wind_accel
    position = position
      + timestep * velocity
```

This still generalizes nicely to modern GPU hardware, although as complexity rises, more advanced GPU languages like CUDA may be more appropriate

45

## Common particle system design

1. Particles are generated from an *emitter* with initial mass, position, velocity
  - a. Emit rate, direction, flow, etc are often specified as a bounded random range (monte carlo)
2. Time ticks; at each tick, particles move by  $dt * velocity$ 
  - a. New particles are generated; expired particles are deleted
  - b. Forces (gravity, wind, etc) accelerate the velocity of each particle
  - c. Collisions and other interactions update velocity
    - i. Ex: 'density' constraints for liquids
    - ii. Ex: 'spring' constraints for cloth
  - d. Velocity changes position
3. Particles are rendered

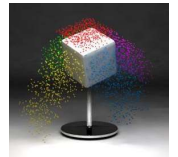

Transient vs persistent particles emitted to create a 'hair' effect (source: Wikipedia)

## Particle systems—rendering

Particles can be rendered as points, textured polys, primitive geometry...

- Polygons with alpha-blended images make pretty good fire, smoke, etc

Transitioning one particle type to another creates realistic interactive effects

- Ex: a 'rain' particle becomes an emitter for 'splash' particles on impact

*Implicit surfaces* or *ellipsoid splatting* are popular algorithms for rendering particle system point clouds as liquid surfaces

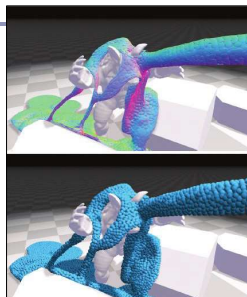

Ihmsen, Markus & Orthmann, Jens & Solenthaler, Barbara & Kolb, Andreas & Teschner, Matthias (2014). *SPH Fluids in Computer Graphics - Eurographics State-of-the-art report*

## “The Genesis Effect” – William Reeves *Star Trek II: The Wrath of Khan* (1982)





## References

### Implicit modelling

- D. Ricci, *A Constructive Geometry for Computer Graphics*, Computer Journal, May 1973
- J Bloomenthal, *Polygonization of Implicit Surfaces*, Computer Aided Geometric Design, Issue 5, 1988
- B Wyvill, C McPheeters, G Wyvill, *Soft Objects*, Advanced Computer Graphics (Proc. CG Tokyo 1986)
- B Wyvill, C McPheeters, G Wyvill, *Animating Soft Objects*, The Visual Computer, Issue 4 1986

### Marching Cubes

- [www.youtube.com/watch?v=M3il210lrhE](http://www.youtube.com/watch?v=M3il210lrhE) (very nice visualization)

### Particle Systems

- William T. Reeves, "Particle Systems - A Technique for Modeling a Class of Fuzzy Objects", Computer Graphics 17:3 pp. 359-376, 1983 (SIGGRAPH 83).
- David Baraff, Andrew Witkin, *Large Steps in Cloth Simulation*, SIGGRAPH 1998
- Leif Kobbelt and Mario Botsch, *A survey of point-based techniques in computer graphics*, Computers & Graphics Volume 28, Issue 6, December 2004, Pages 801-814
- Ihmsen, Markus & Orthmann, Jens & Solenthaler, Barbara & Kolb, Andreas & Teschner, Matthias. (2014). *SPH Fluids in Computer Graphics - Eurographics State-of-the-art report*
- [www.gdcvault.com/play/1024344/D3D-Async-Compute-for-Physics](http://www.gdcvault.com/play/1024344/D3D-Async-Compute-for-Physics) (nice summary)
- [nullprogram.com/webgl-particles/](http://nullprogram.com/webgl-particles/) (nice browser-based demo)

49

## Lecture 3

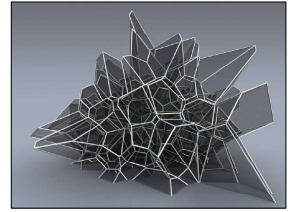

## A Brief Introduction to Computational Geometry

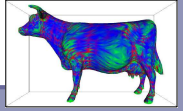

50

Alex Benton, University of Cambridge – alex@bentonian.com  
Supported in part by Google UK, Ltd

## Computational Geometry

- Polygons meshes are examples of *discrete* (as opposed to continuous) representation of geometry
  - Many rendering systems limit themselves to triangle meshes
  - Many require that the mesh be *manifold*
- In a *closed manifold* polygon mesh:
  - Exactly two triangles meet at each edge
  - The faces meeting at each vertex belong to a single, connected loop of faces
- In a *manifold with boundary*:
  - At most two triangles meet at each edge
  - The faces meeting at each vertex belong to a single, connected strip of faces

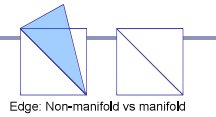

Edge: Non-manifold vs manifold

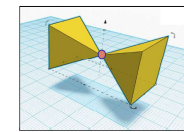

Non-manifold vertex

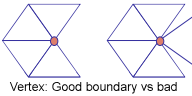

Vertex: Good boundary vs bad

This slide draws much inspiration from Shirley and Marschner's 51 *Fundamentals of Computer Graphics*, pp. 262-263

## Terminology

- We say that a surface is *oriented* if:
  - the vertices of every face are stored in a fixed order
  - if vertices  $i, j$  appear in both faces  $f1$  and  $f2$ , then the vertices appear in order  $i, j$  in one and  $j, i$  in the other
- We say that a surface is *embedded* if, informally, "nothing pokes through":
  - No vertex, edge or face shares any point in space with any other vertex, edge or face except where dictated by the data structure of the polygon mesh
- A closed, embedded surface must separate 3-space into two parts: a bounded *interior* and an unbounded *exterior*.

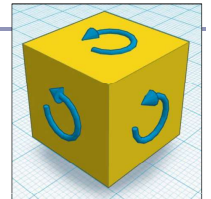

A cube with "anti-clockwise" oriented faces

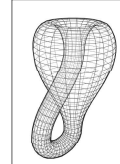

Klein bottle: not an embedded surface. Also, terrible for holding drinks.

This slide draws much inspiration from Hughes and Van Dam's 52 *Computer Graphics: Principles and Practice*, pp. 637-642

## Gaussian curvature on smooth surfaces

Informally speaking, the *curvature* of a surface expresses "how flat the surface isn't".

- One can measure the directions in which the surface is curving *most*; these are the directions of *principal curvature*,  $k_1$  and  $k_2$ .
- The product of  $k_1$  and  $k_2$  is the scalar *Gaussian curvature*.

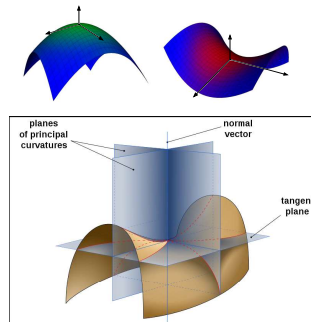

Image by Eric Gaba, from Wikipedia

53

## Gaussian curvature on smooth surfaces

Formally, the *Gaussian curvature* of a region on a surface is the ratio between the **area of the surface of the unit sphere swept out by the normals of that region** and the **area of the region itself**.

The Gaussian curvature of a point is the limit of this ratio as the region tends to zero area.

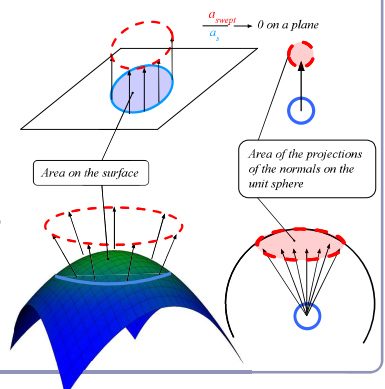

$$\frac{a_{\text{sweep}}}{a_r} \rightarrow r^2 \text{ on a sphere of radius } r$$

(please pretend that this is a sphere)

54

## Gaussian curvature on discrete surfaces

On a discrete surface, normals do not vary smoothly: the normal to a face is constant on the face, and at edges and vertices the normal is—strictly speaking—undefined.

- Normals change instantaneously (as one's point of view travels across an edge from one face to another) or not at all (as one's point of view travels within a face.)

The Gaussian curvature of the surface of any polyhedral mesh is **zero** everywhere except at the vertices, where it is **infinite**.

55

## Normal on a surface

Expressed as a limit,

The *normal of surface  $S$  at point  $P$*  is the limit of the cross-product between two (non-collinear) vectors from  $P$  to the set of points in  $S$  at a distance  $r$  from  $P$  as  $r$  goes to zero. [Excluding orientation.]

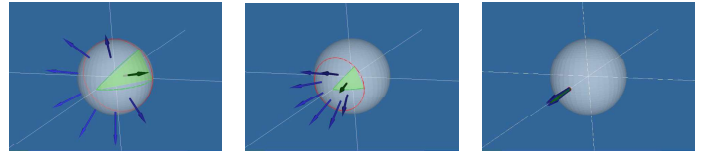

56

## Normal at a vertex

Using the limit definition, is the ‘normal’ to a discrete surface necessarily a vector?

- The normal to the surface at any point on a face is a constant vector.
- The ‘normal’ to the surface at any edge is an arc swept out on a unit sphere between the two normals of the two faces.
- The ‘normal’ to the surface at a vertex is a space swept out on the unit sphere between the normals of all of the adjacent faces.

57

## Finding the normal at a vertex

Method 1: Take the average of the normals of surrounding polygons

Problem: splitting one adjacent face into 10,000 shards would skew the average

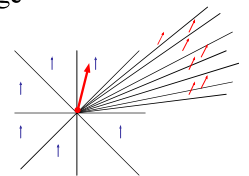
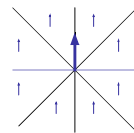

58

## Finding the normal at a vertex

Method 2: Take the weighted average of the normals of surrounding polygons, weighted by the area of each face

- 2a: Weight each face normal by the area of the face divided by the total number of vertices in the face

Problem: Introducing new edges into a neighboring face (and thereby reducing its area) should not change the normal.

Should making a face larger affect the normal to the surface near its corners?

- Argument for yes: If the vertices interpolate the ‘true’ surface, then stretching the surface at a distance could still change the local normals.

59

## Finding the normal at a vertex

Method 3: Take the weighted average of the normals of surrounding polygons, weighted by each polygon’s *face angle* at the vertex

*Face angle*: the angle  $\alpha$  formed at the vertex  $v$  by the vectors to the next and previous vertices in the face  $F$

$$\alpha(F, v_i) = \cos^{-1} \left( \frac{v_{i+1} - v_i}{|v_{i+1} - v_i|} \cdot \frac{v_{i-1} - v_i}{|v_{i-1} - v_i|} \right)$$

$$N(v) = \frac{\sum_F \alpha(F, v) N_F}{|\sum_F \alpha(F, v)|}$$

Note: In this equation, *arccos* implies a convex polygon. Why?

60

## Angle deficit – a better solution for measuring discrete curvature

The *angle deficit*  $AD(v)$  of a vertex  $v$  is defined to be two  $\pi$  minus the sum of the *face angles*  $\alpha(F)$  of the adjacent faces

$$\alpha(F, v_i) = \cos^{-1} \left( \frac{v_{i+1} - v_i}{|v_{i+1} - v_i|} \cdot \frac{v_{i-1} - v_i}{|v_{i-1} - v_i|} \right)$$

$$AD(v) = 2\pi - \sum_F \alpha(F, v)$$

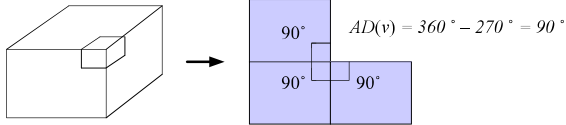

61

## Angle deficit

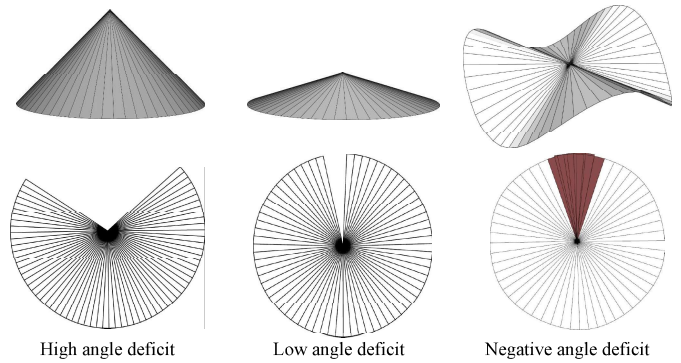

High angle deficit

Low angle deficit

Negative angle deficit

62

## Angle deficit

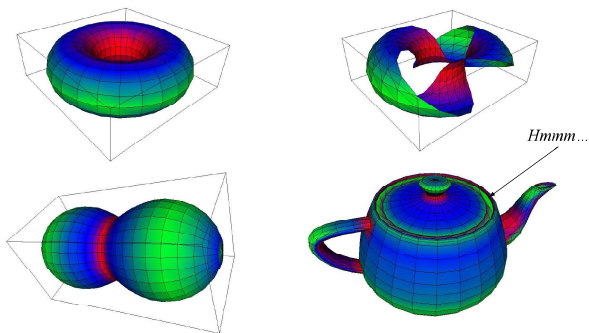

63

## Genus, Poincaré and the Euler Characteristic

- Formally, the *genus*  $g$  of a closed surface is

...“a topologically invariant property of a surface defined as the largest number of nonintersecting simple closed curves that can be drawn on the surface without separating it.”

--mathworld.com

- Informally, it's the number of coffee cup handles in the surface.

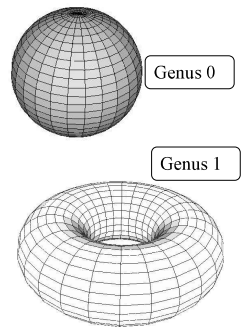

64

## Genus, Poincaré and the Euler Characteristic

Given a polyhedral surface  $S$  without border where:

- $V$  = the number of vertices of  $S$ ,
- $E$  = the number of edges between those vertices,
- $F$  = the number of faces between those edges,
- $\chi$  is the *Euler Characteristic* of the surface,

the Poincaré Formula states that:

$$V - E + F = 2 - 2g = \chi$$

65

## Genus, Poincaré and the Euler Characteristic

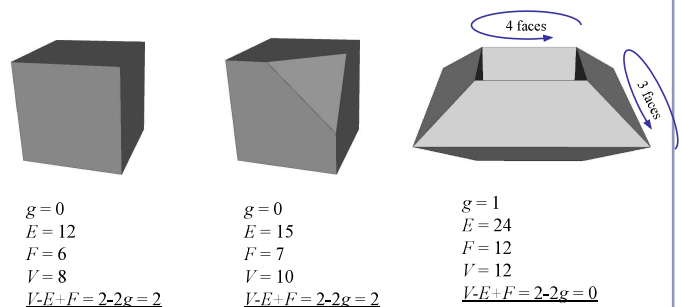

$$g = 0$$

$$E = 12$$

$$F = 6$$

$$V = 8$$

$$V - E + F = 2 - 2g = 2$$

$$g = 0$$

$$E = 15$$

$$F = 7$$

$$V = 10$$

$$V - E + F = 2 - 2g = 2$$

$$g = 1$$

$$E = 24$$

$$F = 12$$

$$V = 12$$

$$V - E + F = 2 - 2g = 0$$

66

## The Euler Characteristic and angle deficit

Descartes' *Theorem of Total Angle Deficit* states that on a surface  $S$  with Euler characteristic  $\chi$ , the sum of the angle deficits of the vertices is  $2\pi\chi$ :

$$\sum_S AD(v) = 2\pi\chi$$

Cube:

- $\chi = 2 - 2g = 2$
- $AD(v) = \pi/2$
- $8(\pi/2) = 4\pi = 2\pi\chi$

Tetrahedron:

- $\chi = 2 - 2g = 2$
- $AD(v) = \pi$
- $4(\pi) = 4\pi = 2\pi\chi$

67

## Speed things up!

### Bounding volumes

A common optimization method for ray-based rendering is the use of *bounding volumes*.

Great for...

- Collision detection between scene elements
- Culling before rendering
- Accelerating ray-tracing, -marching

Nested bounding volumes allow the rapid culling of large portions of geometry

- Test against the bounding volume of the top of the scene graph and then work down.

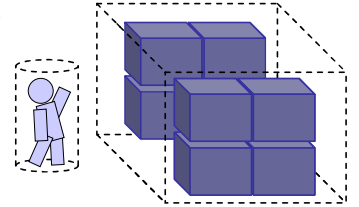

68

## Popular acceleration structures: Octrees

Split space into cells and list in each cell every object in the scene that overlaps that cell.

- The ray can skip empty cells
- Requires preprocessing stage, but can be partially updated for moving scenes
- Popular for voxelized games
- The Octree data structure generalizes to arbitrary  $n$ -sided rectangular volume subdivision

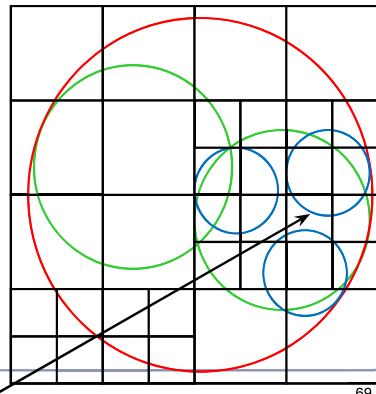

69

## Popular acceleration structures: BSP Trees

The *BSP tree* pre-partitions the scene into objects in front of, on, and behind a tree of planes.

- This gives an ordering in which to test scene objects against your ray
- When you fire a ray into the scene, you test all near-side objects before testing far-side objects.

Challenges:

- requires slow pre-processing step
- strongly favors static scenes
- choice of planes is hard to optimize

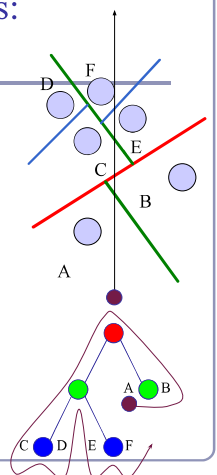

70

## Popular acceleration structures: *kd-trees*

The *kd-tree* is a simplification of the BSP Tree data structure

- Space is recursively subdivided by axis-aligned planes and points on either side of each plane are separated in the tree.
- The *kd-tree* has  $O(n \log n)$  insertion time (but this is very optimizable by domain knowledge) and  $O(n^{2/3})$  search time.
- *kd-trees* don't suffer from the mathematical slowdowns of BSPs because their planes are always axis-aligned.

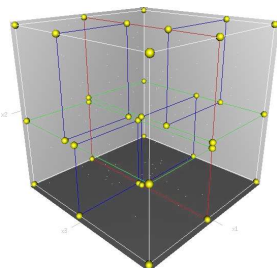

Image from Wikipedia, bless their hearts.

71

## Popular acceleration structures: *Bounding Interval Hierarchies*

The *Bounding Interval Hierarchy* subdivides space around the volumes of objects and shrinks each volume to remove unused space.

- Think of this as a "best-fit" *kd-tree*
- Can be built dynamically as each ray is fired into the scene
- Retains implicit contents sorting, which is nice for traversal

Image from Wächter and Keller's paper, *Instant Ray Tracing: The Bounding Interval Hierarchy*, Eurographics (2006)

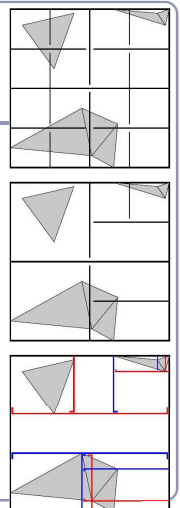

72

## Convex hull

The *convex hull* of a set of points is the unique surface of least area which contains the set.

- If a set of infinite half-planes have a finite non-empty intersection, then the surface of their intersection is a convex polyhedron.
- If a polyhedron is convex then for any two faces A and B in the polyhedron, all points in B which are not in A lie to the same side of the plane containing A.

Every point on a convex hull has non-negative angle deficit.

The faces of a convex hull are always convex.

73

## Finding the convex hull of a set of points

Method 1: For every triple of points in the set, define a plane  $P$ . If all other points in the set lie to the same side of  $P$  (dot-product test) then add  $P$  to the hull; else discard.

Problem 1: this works but it's  $O(n^3)$ .

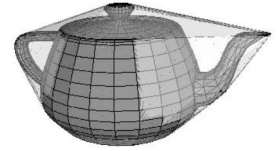

74

## Finding the convex hull of a set of points

Method 2:

- Initialize  $C$  with a tetrahedron from any four non-colinear points in the set. Orient the faces of  $C$  by taking the dot product of the center of each face with the average of the vertices of  $C$ .
- For each vertex  $v$ ,
  - For each face  $f$  of  $C$ ,
    - If the dot product of the normal of  $f$  with the vector from the center of  $f$  to  $v$  is positive then  $v$  is 'above'  $f$ .
    - If  $v$  is above  $f$  then delete  $f$  and update a (sorted) list of all new border vertices.
  - Create a new triangular face from  $v$  to each pair of border vertices.

Time complexity:  $O(n^2)$

75

## Testing if a point is inside a convex hull

We can generalize Method 2 to test whether a point is inside any convex polyhedron.

- For each face, test the dot product of the normal of the face with a vector from the face to the point. If the dot is ever positive, the point lies outside.
- The same logic applies if you're storing normals at vertices.

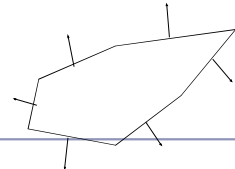

76

## References

### Voronoi diagrams

- M. de Berg, O. Cheong, M. van Kreveld, M. Overmars, "Computational Geometry: Algorithms and Applications", Springer-Verlag,
- <http://www.cs.uu.nl/geobook/>
- <http://www.ics.uci.edu/~eppstein/junkyard/mn.html>
- <http://www.iquilezles.org/www/articles/voronoinlines/voronoinlines.htm>

### Gaussian Curvature

- [http://en.wikipedia.org/wiki/Gaussian\\_curvature](http://en.wikipedia.org/wiki/Gaussian_curvature)
- <http://mathworld.wolfram.com/GaussianCurvature.html>

### The Poincaré Formula

- <http://mathworld.wolfram.com/PoincareFormula.html>

77

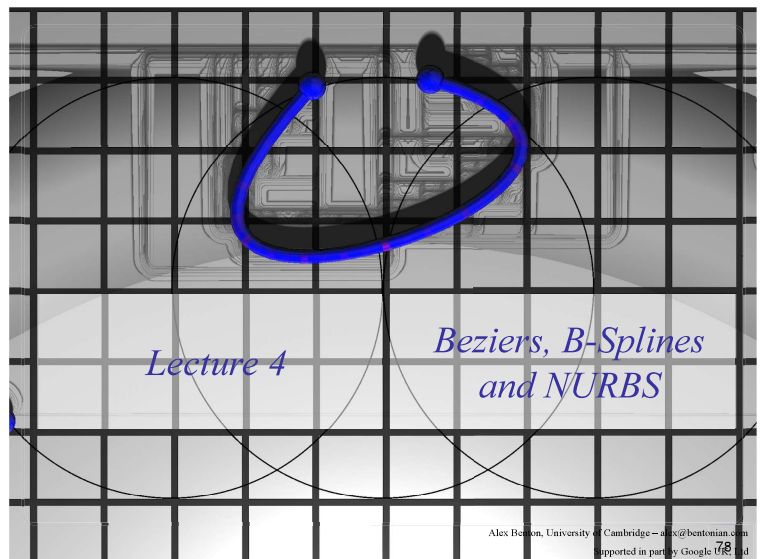

## CAD, CAM, and a new motivation: shiny things

Expensive products are sleek and smooth.  
 → Expensive products are C2 continuous.



Shiny, but reflections are warped

Shiny, and reflections are perfect

## The drive for smooth CAD/CAM

- *Continuity* (smooth curves) can be essential to the perception of *quality*.
- The automotive industry wanted to design cars which were aerodynamic, but also visibly of high quality.
- Bezier (Renault) and de Casteljaou (Citroen) invented Bezier curves in the 1960s. de Boor (GM) generalized them to B-splines.



## History

The term *spline* comes from the shipbuilding industry: long, thin strips of wood or metal would be bent and held in place by heavy 'ducks', lead weights which acted as control points of the curve.

Wooden splines can be described by  $C_n$ -continuous Hermite polynomials which interpolate  $n+1$  control points.

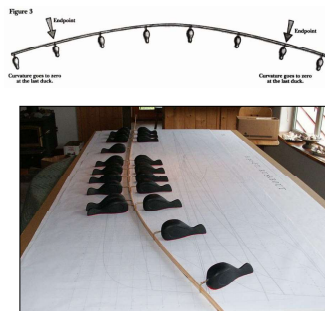

Top: Fig 3, P.7, Bray and Spectre, *Planking and Fastening*, Wooden Boat Pub (1996)  
 Bottom: [http://www.pranos.com/boatsofwood/lofting%20ducks/lofting\\_ducks.htm](http://www.pranos.com/boatsofwood/lofting%20ducks/lofting_ducks.htm)

## Bezier cubic

- A *Bezier cubic* is a function  $P(t)$  defined by four control points:

$$P(t) = (1-t)^3 P_0 + 3t(1-t)^2 P_1 + 3t^2(1-t) P_2 + t^3 P_3$$

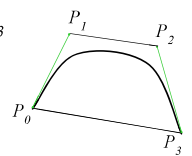

- $P_0$  and  $P_3$  are the endpoints of the curve
- $P_1$  and  $P_2$  define the other two corners of the bounding polygon.
- The curve fits entirely within the convex hull of  $P_0 \dots P_3$ .

## Beziers

Cubics are just one example of Bezier splines:

- **Linear:**  $P(t) = (1-t)P_0 + tP_1$
- **Quadratic:**  $P(t) = (1-t)^2 P_0 + 2t(1-t)P_1 + t^2 P_2$
- **Cubic:**  $P(t) = (1-t)^3 P_0 + 3t(1-t)^2 P_1 + 3t^2(1-t) P_2 + t^3 P_3$

...

General:

$$P(t) = \sum_{i=0}^n \binom{n}{i} (1-t)^{n-i} t^i P_i, \quad 0 \leq t \leq 1$$

"n choose i" =  $n! / i!(n-i)!$

## Beziers

- You can describe Beziers as *nested linear interpolations*:
  - The linear Bezier is a linear interpolation between two points:  
 $P(t) = (1-t)(P_0) + t(P_1)$
  - The quadratic Bezier is a linear interpolation between two lines:  
 $P(t) = (1-t)((1-t)P_0 + tP_1) + t((1-t)P_1 + tP_2)$
  - The cubic is a linear interpolation between linear interpolations between linear interpolations... etc.
- Another way to see Beziers is as a *weighted average* between the control points.

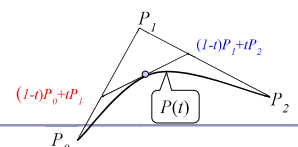

## Bernstein polynomials

$$P(t) = \underbrace{(1-t)^3}_{P_0} + \underbrace{3t(1-t)^2}_{P_1} + \underbrace{3t^2(1-t)}_{P_2} + \underbrace{t^3}_{P_3}$$

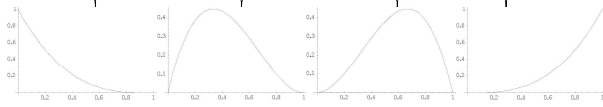

- The four control functions are the four *Bernstein polynomials* for  $n=3$ .

- General form:  $b_{v,n}(t) = \binom{n}{v} t^v (1-t)^{n-v}$

- Bernstein polynomials in  $0 \leq t \leq 1$  always sum to 1:

$$\sum_{v=1}^n \binom{n}{v} t^v (1-t)^{n-v} = (t + (1-t))^n = 1$$

85

## Types of curve join

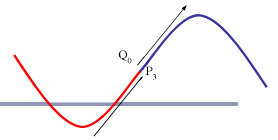

- each curve is smooth within itself
- joins at endpoints can be:
  - $C_1$  – continuous in both position and tangent vector
    - smooth join in a mathematical sense
  - $G_1$  – continuous in position, tangent vector in same direction
    - smooth join in a geometric sense
  - $C_0$  – continuous in position only
    - “corner”
  - discontinuous in position

$C_n$  (mathematical continuity): continuous in all derivatives up to the  $n^{\text{th}}$  derivative

$G_n$  (geometric continuity): each derivative up to the  $n^{\text{th}}$  has the same “direction” to its vector on either side of the join

$$C_n \Rightarrow G_n$$

86

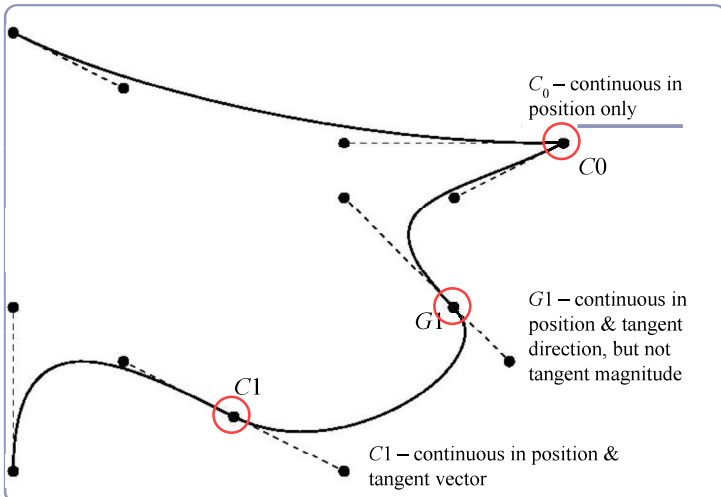

$C_0$  – continuous in position only

$C_0$

$G_1$  – continuous in position & tangent direction, but not tangent magnitude

$C_1$  – continuous in position & tangent vector

87

## Joining Bezier splines

- To join two Bezier splines with  $C_0$  continuity, set  $P_3 = Q_0$ .
- To join two Bezier splines with  $C_1$  continuity, require  $C_0$  and make the tangent vectors equal: set  $P_3 = Q_0$  and  $P_3 - P_2 = Q_1 - Q_0$ .

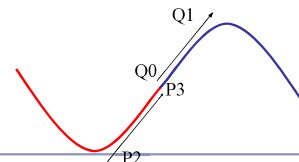

88

## What if we want to chain Bezier together?

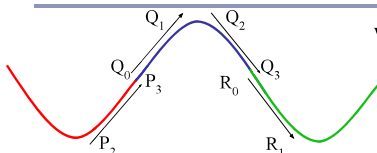

We can parameterize this chain over  $t$  by saying that instead of going from 0 to 1,  $t$  moves smoothly through the intervals  $[0, 1, 2, 3]$

Consider a chain of splines with many control points...

$$P = \{P_0, P_1, P_2, P_3\}$$

$$Q = \{Q_0, Q_1, Q_2, Q_3\}$$

$$R = \{R_0, R_1, R_2, R_3\}$$

... with  $C_1$  continuity...

$$P_3 = Q_0, P_2 - P_3 = Q_1 - Q_0$$

$$Q_3 = R_0, Q_2 - Q_3 = R_1 - R_0$$

The curve  $C(t)$  would be:

$$C(t) = P(t) \cdot ((0 \leq t < 1) ? 1 : 0) + Q(t-1) \cdot ((1 \leq t < 2) ? 1 : 0) + R(t-2) \cdot ((2 \leq t < 3) ? 1 : 0)$$

$[0, 1, 2, 3]$  is a type of *knot vector*.  
0, 1, 2, and 3 are the *knots*.

89

## B-Splines

B-Splines (“Basis Splines”) are a generalization of Bezier. B-splines are built from a series of splines, joined with known continuity.

- A B-spline curve is defined between  $t_{min}$  and  $t_{max}$ :

$$P(t) = \sum_{i=1}^n N_{i,k}(t) P_i, \quad t_{min} \leq t < t_{max}$$

- $N_{i,k}(t)$  is the *basis function* of control point  $P_i$  for parameter  $k$ .  $N_{i,k}(t)$  is defined recursively:

$$N_{i,1}(t) = \begin{cases} 1, & t_i \leq t < t_{i+1} \\ 0, & \text{otherwise} \end{cases}$$

$$N_{i,k}(t) = \frac{t - t_i}{t_{i+k-1} - t_i} N_{i,k-1}(t) + \frac{t_{i+k} - t}{t_{i+k} - t_{i+1}} N_{i+1,k-1}(t)$$

90

## B-Splines

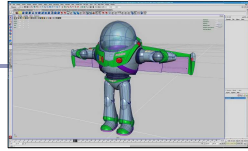

B-splines are defined by:

- $\{P_1, \dots, P_n\}$ , the list of  $n$  control points
- $d$ , the degree of the curve
- $k = d + 1$ , called the parameter of the curve
- $[t_1, \dots, t_{k+n}]$ , a knot vector of  $(k+n)$  parameter values ("knots")

A B-spline curve will have the following traits:

- $d = k - 1$  is the degree of the curve, so  $k$  is the number of control points which influence a single interval
  - Ex: a cubic ( $d=3$ ) has four control points ( $k=4$ )
- There are  $k+n$  knots  $t_p$  and  $t_i \leq t_{i+1}$  for all  $t_i$
- Each B-spline is  $C_{(k-2)}$  continuous: continuity is degree minus one, so a  $k=3$  curve has  $d=2$  and is  $C1$

<http://www.mikekrummboisjens.com/love-story-01-09-91>

## B-Splines

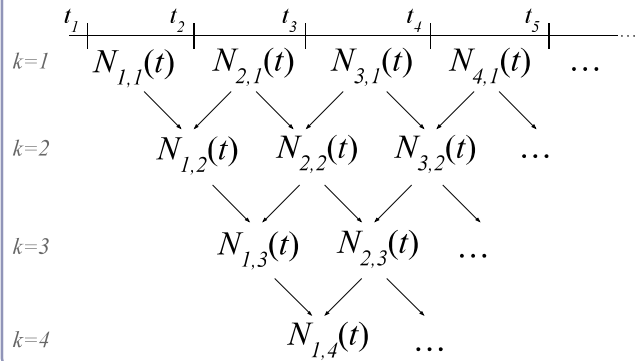

92

## B-Splines

$$N_{i,1}(t) = \begin{cases} 1, & t_i \leq t < t_{i+1} \\ 0, & \text{otherwise} \end{cases}$$

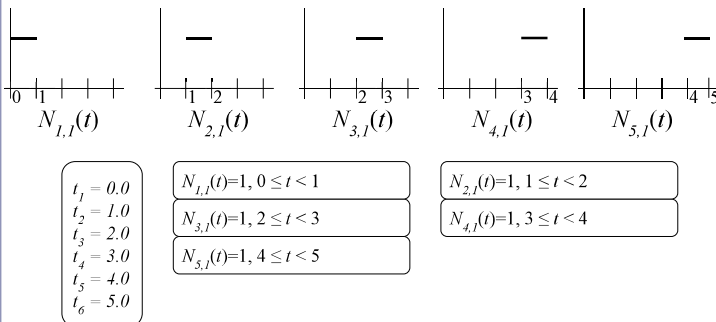

Knot vector =  $\{0, 1, 2, 3, 4, 5\}$ ,  $k = 1 \rightarrow d = 0$  (degree = zero) 93

## B-Splines

$$N_{i,k}(t) = \frac{t - t_i}{t_{i+k-1} - t_i} N_{i,k-1}(t) + \frac{t_{i+k} - t}{t_{i+k} - t_{i+1}} N_{i+1,k-1}(t)$$

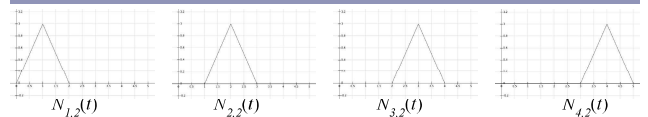

$$N_{1,2}(t) = \frac{t-0}{1-0}N_{1,1}(t) + \frac{2-t}{2-1}N_{2,1}(t) = \begin{cases} t & 0 \leq t < 1 \\ 2-t & 1 \leq t < 2 \end{cases}$$

$$N_{2,2}(t) = \frac{t-1}{2-1}N_{2,1}(t) + \frac{3-t}{3-2}N_{3,1}(t) = \begin{cases} t-1 & 1 \leq t < 2 \\ 3-t & 2 \leq t < 3 \end{cases}$$

$$N_{3,2}(t) = \frac{t-2}{3-2}N_{3,1}(t) + \frac{4-t}{4-3}N_{4,1}(t) = \begin{cases} t-2 & 2 \leq t < 3 \\ 4-t & 3 \leq t < 4 \end{cases}$$

$$N_{4,2}(t) = \frac{t-3}{4-3}N_{4,1}(t) + \frac{5-t}{5-4}N_{5,1}(t) = \begin{cases} t-3 & 3 \leq t < 4 \\ 5-t & 4 \leq t < 5 \end{cases}$$

Knot vector =  $\{0, 1, 2, 3, 4, 5\}$ ,  $k = 2 \rightarrow d = 1$  (degree = one) 94

## B-Splines

$$N_{i,k}(t) = \frac{t - t_i}{t_{i+k-1} - t_i} N_{i,k-1}(t) + \frac{t_{i+k} - t}{t_{i+k} - t_{i+1}} N_{i+1,k-1}(t)$$

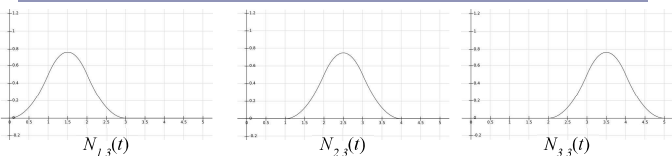

$$N_{1,3}(t) = \frac{t-0}{2-0}N_{1,2}(t) + \frac{3-t}{3-1}N_{2,2}(t) = \begin{cases} t^2/2 & 0 \leq t < 1 \\ -t^2 + 3t - 3/2 & 1 \leq t < 2 \\ (3-t)^2/2 & 2 \leq t < 3 \end{cases}$$

$$N_{2,3}(t) = \frac{t-1}{3-1}N_{2,2}(t) + \frac{4-t}{4-2}N_{3,2}(t) = \begin{cases} (t-1)^2/2 & 1 \leq t < 2 \\ -t^2 + 5t - 11/2 & 2 \leq t < 3 \\ (4-t)^2/2 & 3 \leq t < 4 \end{cases}$$

$$N_{3,3}(t) = \frac{t-2}{4-2}N_{3,2}(t) + \frac{5-t}{5-3}N_{4,2}(t) = \begin{cases} (t-2)^2/2 & 2 \leq t < 3 \\ -t^2 + 7t - 23/2 & 3 \leq t < 4 \\ (5-t)^2/2 & 4 \leq t < 5 \end{cases}$$

Knot vector =  $\{0, 1, 2, 3, 4, 5\}$ ,  $k = 3 \rightarrow d = 2$  (degree = two) 95

## Basis functions really sum to one (k=2)

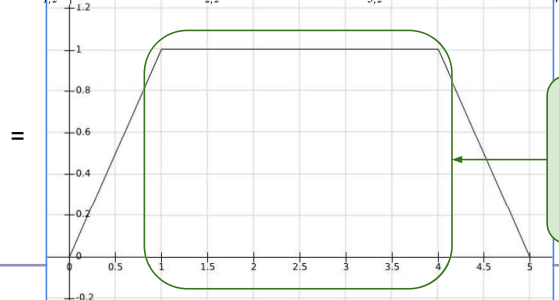
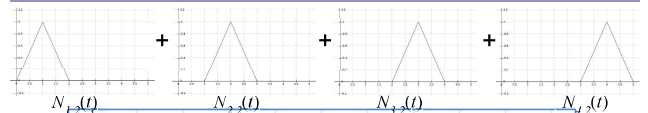

The sum of the four basis functions is fully defined (sums to one) between  $t_2$  ( $t=1.0$ ) and  $t_3$  ( $t=4.0$ ).

96



## Basis functions really sum to one (k=3)

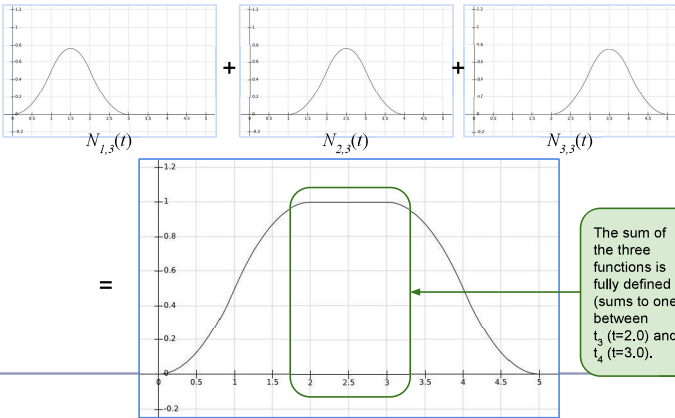

97

## B-Splines

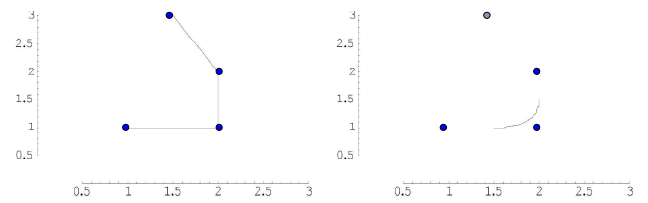

At  $k=2$  the function is piecewise linear, depends on  $P_1, P_2, P_3, P_4$ , and is fully defined on  $[t_2, t_3]$ .

At  $k=3$  the function is piecewise quadratic, depends on  $P_1, P_2, P_3$ , and is fully defined on  $[t_3, t_4]$ .

Each parameter- $k$  basis function depends on  $k+1$  knot values;  $N_{i,k}$  depends on  $t_i$  through  $t_{i+k}$ , inclusive. So six knots  $\rightarrow$  five discontinuous functions  $\rightarrow$  four piecewise linear interpolations  $\rightarrow$  three quadratics, interpolating three control points.  $n=3$  control points,  $d=2$  degree,  $k=3$  parameter,  $n+k=6$  knots.

Knot vector =  $\{0, 1, 2, 3, 4, 5\}$

98

## Non-Uniform B-Splines

- The knot vector  $\{0, 1, 2, 3, 4, 5\}$  is *uniform*:  
 $t_{i+1} - t_i = t_{i+2} - t_{i+1} \forall t_i$
- Varying the size of an interval changes the parametric-space distribution of the weights assigned to the control functions.
- Repeating a knot value reduces the continuity of the curve in the affected span by one degree.
- Repeating a knot  $k$  times will lead to a control function being influenced only by that knot value; the spline will pass through the corresponding control point with  $C_0$  continuity.

99

## Open vs Closed

- A knot vector which repeats its first and last knot values  $k$  times is called *open* (or 'clamped'), otherwise *closed*.
  - Repeating the knots  $k$  times is the only way to force the curve to pass through the first or last control point.
  - Without this, the functions  $N_{1,k}$  and  $N_{n,k}$  (which weight  $P_1$  and  $P_n$ ) would still be 'ramping up' and not yet equal to one at the first and last  $t$ .

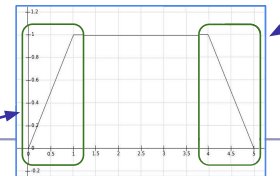

100

## Open vs Closed

- Two open examples you may recognize:
  - $k=3, n=3$  control points, knots= $\{0, 0, 0, 1, 1, 1\}$
  - $k=4, n=4$  control points, knots= $\{0, 0, 0, 0, 1, 1, 1, 1\}$

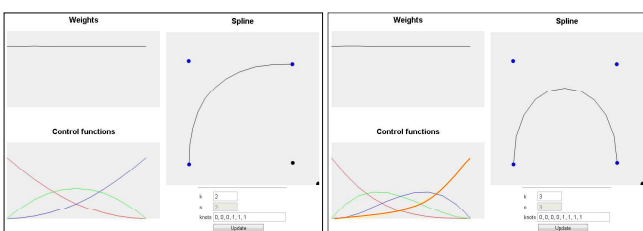

101

## NURBS curves

- NURBS** ("Non-Uniform Rational B-Splines") are a generalization of the Bezier curve concept:
  - NU: Non-Uniform.** The knots in the knot vector are not required to be uniformly spaced.
  - R: Rational.** The spline may be defined by rational polynomials (homogeneous coordinates.)
  - BS: B-Spline.** A generalization of Bezier splines with controllable degree.

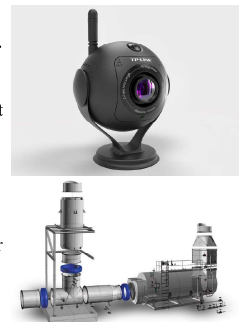

Images from [www.rhino3d.com/galten102](http://www.rhino3d.com/galten102)

## Non-Uniform Rational B-Splines

- Repeating knot values is a clumsy way to control the curve's proximity to the control point.
  - We want to be able to slide the curve nearer or farther without losing continuity or introducing new control points.
  - The solution: *homogeneous coordinates*.
  - Associate a 'weight' with each control point:  $\omega_i$ .

103

## Non-Uniform Rational B-Splines

- Recall:  $[x, y, z, \omega]_H \rightarrow [x/\omega, y/\omega, z/\omega]$ 
  - Or:  $[x, y, z, 1] \rightarrow [x\omega, y\omega, z\omega, \omega]_H$
- The control point  $P_i = (x_i, y_i, z_i)$  becomes the homogeneous control point  $P_{iH} = (x_i\omega_i, y_i\omega_i, z_i\omega_i)$
- A NURBS in homogeneous coordinates is:
 
$$P_H(t) = \sum_{i=1}^n N_{i,k}(t) P_{iH}, \quad t_{min} \leq t < t_{max}$$

104

## Non-Uniform Rational B-Splines

- To convert from homogeneous coords to normal coordinates:

$$\begin{aligned} x_H(t) &= \sum_{i=1}^n (x_i \omega_i) (N_{i,k}(t)) \\ y_H(t) &= \sum_{i=1}^n (y_i \omega_i) (N_{i,k}(t)) \\ z_H(t) &= \sum_{i=1}^n (z_i \omega_i) (N_{i,k}(t)) \\ \omega(t) &= \sum_{i=1}^n (\omega_i) (N_{i,k}(t)) \end{aligned}$$

$$\begin{aligned} x(t) &= x_H(t) / \omega(t) \\ y(t) &= y_H(t) / \omega(t) \\ z(t) &= z_H(t) / \omega(t) \end{aligned}$$

105

## Non-Uniform Rational B-Splines

- A piecewise rational curve is thus defined by:

$$P(t) = \sum_{i=1}^n R_{i,k}(t) P_i, \quad t_{min} < t_{max}$$

with supporting *rational basis functions*:

$$R_{i,k}(t) = \frac{\omega_i N_{i,k}(t)}{\sum_{j=1}^n \omega_j N_{j,k}(t)}$$

This is essentially an average re-weighted by the  $\omega$ 's.

- Such a curve can be made to pass arbitrarily far or near to a control point by changing the corresponding weight.

106

## References

- Les Piegl and Wayne Tiller, *The NURBS Book*, Springer (1997)
- Alan Watt, *3D Computer Graphics*, Addison Wesley (2000)
- G. Farin, J. Hoschek, M.-S. Kim, *Handbook of Computer Aided Geometric Design*, North-Holland (2002)

107

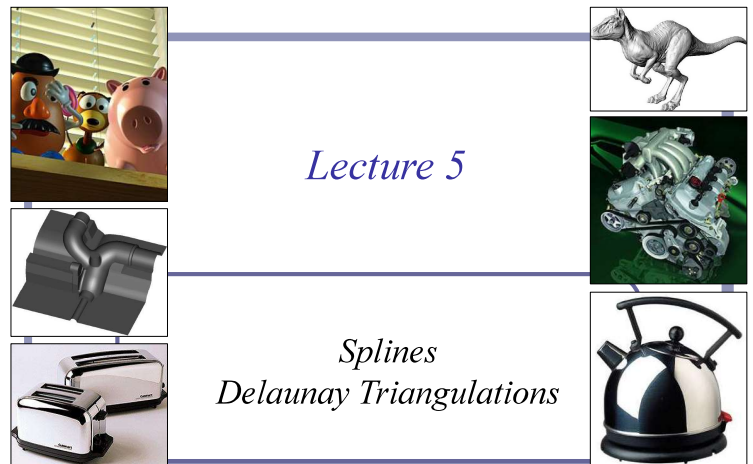

*Lecture 5*

*Splines*  
*Delaunay Triangulations*

108

## Drawing a Bezier cubic: Iterative method

Fixed-step iteration:

- Draw as a set of short line segments equispaced in parameter space,  $t$ :

```
(x0,y0) = Bezier(0)
FOR t = 0.05 TO 1 STEP 0.05 DO
  (x1,y1) = Bezier(t)
  DrawLine( (x0,y0), (x1,y1) )
  (x0,y0) = (x1,y1)
END FOR
```

- Problems:
  - Cannot fix a number of segments that is appropriate for all possible Beziers: too many or too few segments
  - distance in real space,  $(x,y)$ , is not linearly related to distance in parameter space,  $t$

109

## Drawing a Bezier cubic

...but not very well

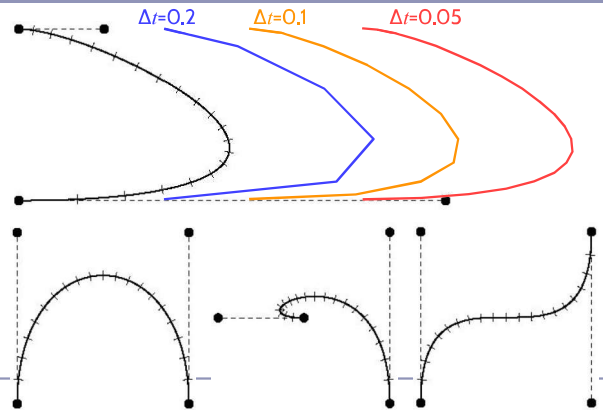

110

## Drawing a Bezier cubic: Adaptive method

- Subdivision:
  - check if a straight line between  $P_0$  and  $P_3$  is an adequate approximation to the Bezier
  - if so: draw the straight line
  - if not: divide the Bezier into two halves, each a Bezier, and repeat for the two new Beziers
- Need to specify some tolerance for when a straight line is an adequate approximation
  - when the Bezier lies within half a pixel width of the straight line along its entire length

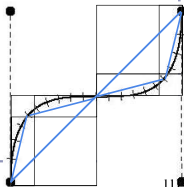

111

## Drawing a Bezier cubic: Adaptive method

```
Procedure DrawCurve( Bezier curve )
VAR Bezier left, right
BEGIN DrawCurve
  IF Flat(curve) THEN
    DrawLine(curve)
  ELSE
    SubdivideCurve(curve, left, right)
    DrawCurve(left)
    DrawCurve(right)
  END IF
END DrawCurve
```

e.g. if  $P_1$  and  $P_2$  both lie within half a pixel width of the line joining  $P_0$  to  $P_3$ , then...

...draw a line from  $P_0$  to  $P_3$ ; otherwise,

...split the curve into two Beziers covering the first and second halves of the original and draw recursively

112

## Checking for flatness

$$P(t) = (1-t)A + tB$$

$$AB \cdot CP(t) = 0$$

$$\rightarrow (x_B - x_A)(x_P - x_C) + (y_B - y_A)(y_P - y_C) = 0$$

$$\rightarrow t = \frac{(x_B - x_A)(x_C - x_A) + (y_B - y_A)(y_C - y_A)}{(x_B - x_A)^2 + (y_B - y_A)^2}$$

$$\rightarrow t = \frac{AB \cdot AC}{|AB|^2}$$

Careful! If  $t < 0$  or  $t > 1$ , use  $|AC|$  or  $|BC|$  respectively.

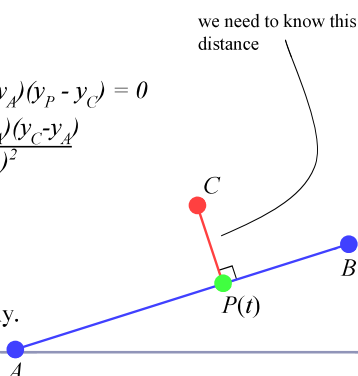

113

## Subdividing a Bezier cubic in two

To split a Bezier cubic into two smaller Bezier cubics:

$$Q_0 = P_0$$

$$Q_1 = \frac{1}{2}P_0 + \frac{1}{2}P_1$$

$$Q_2 = \frac{1}{4}P_0 + \frac{1}{2}P_1 + \frac{1}{4}P_2$$

$$Q_3 = \frac{1}{8}P_0 + \frac{3}{8}P_1 + \frac{3}{8}P_2 + \frac{1}{8}P_3$$

$$R_3 = \frac{1}{8}P_0 + \frac{3}{8}P_1 + \frac{3}{8}P_2 + \frac{1}{8}P_3$$

$$R_2 = \frac{1}{4}P_1 + \frac{1}{2}P_2 + \frac{1}{4}P_3$$

$$R_1 = \frac{1}{2}P_2 + \frac{1}{2}P_3$$

$$R_0 = P_3$$

These cubics will lie atop the halves of their parent exactly, so rendering them = rendering the parent.

114

## Overhauser's cubic

*Overhauser's cubic*: a Bezier cubic which passes through four target data points

- Calculate the appropriate Bezier control point locations from the given data points
  - e.g. given points A, B, C, D, the Bezier control points are:
    - $P_0 = B$        $P_1 = B + (C-A)/6$
    - $P_3 = C$        $P_2 = C - (D-B)/6$
- Overhauser's cubic *interpolates* its controlling points
  - good for animation, movies; less for CAD/CAM
  - moving a single point modifies four adjacent curve segments
  - compare with Bezier, where moving a single point modifies just the two segments connected to that point

115

## Drawing a Bezier cubic: Signed Distance Fields

### 1. Iterative implementation

$SDF(P) = \min(\text{distance from } P \text{ to each of } n \text{ line segments})$

- In the demo, 50 steps suffices

### 2. Adaptive implementation

$SDF(P) = \min(\text{distance to each sub-curve whose bounding box contains } P)$

- Can fast-discard sub-curves whose bbox doesn't contain  $P$
- In the demo, 25 subdivisions suffices

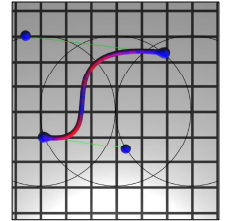
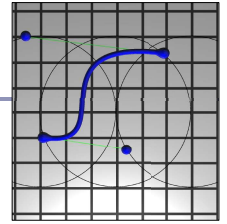

116

## Into the Third Dimension

A Bezier patch can be defined by sixteen control points,

$$\begin{matrix} P_{0,0} & \dots & P_{0,3} \\ \vdots & & \vdots \\ P_{3,0} & \dots & P_{3,3} \end{matrix}$$

The weighted average of these 16 points uses Bernstein polynomials just like the 2D form:

$$P(s, t) = \sum_{i=0}^3 \sum_{j=0}^3 b_i(s) b_j(t) P_{ij}$$

$$b_{v,n}(t) = \binom{n}{v} t^v (1-t)^{n-v}$$

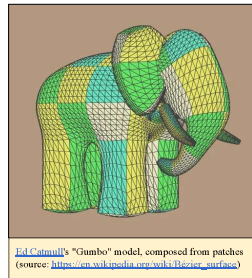

117

## Tensor product $\otimes$

- The *tensor product* of two vectors is a matrix.

$$\begin{bmatrix} a \\ b \\ c \end{bmatrix} \otimes \begin{bmatrix} d \\ e \\ f \end{bmatrix} = \begin{bmatrix} ad & ae & af \\ bd & be & bf \\ cd & ce & cf \end{bmatrix}$$

- Can take the tensor of two polynomials
  - Each coefficient represents a piece of each of the two original expressions, so the cumulative polynomial represents both original polynomials completely

118

## Bezier patches

- If curve A has  $n$  control points and curve B has  $m$  control points then  $A \otimes B$  is an  $(n) \times (m)$  matrix of polynomials of degree  $\max(n-1, m-1)$ .
  - $\otimes$  = tensor product
- Multiply this matrix against an  $(n) \times (m)$  matrix of control points and sum them all up and you've got a bivariate expression for a rectangular surface patch, in 3D
- This approach generalizes to triangles and arbitrary  $n$ -gons.

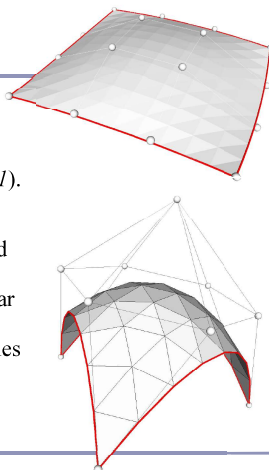

119

## Continuity between Bezier patches

Ensuring continuity in 3D:

- C0 – continuous in position
  - the four edge control points must match
- C1 – continuous in position and tangent vector
  - the four edge control points must match
  - the two control points on either side of each of the four edge control points must be co-linear with both the edge point, and each other, and be equidistant from the edge point
- G1 – continuous in position and tangent direction the four edge control points must match the relevant control points must be co-linear

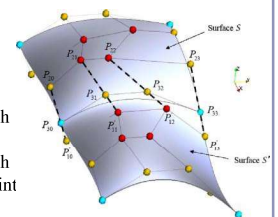

Image credit: Olivier Czarny, Guido Huysmans, Bézier surfaces and finite elements for MHD simulations, Journal of Computational Physics, Volume 227, Issue 16, 10 August 2008

120

## NURBS in 3D

Like Bezier patches, NURBS surfaces are the bivariate generalisation of the univariate NURBS form:

$$P(t) = \sum_{i=1}^n N_{i,k}(t)P_i$$

$$P(s,t) = \sum_{i=1}^m \sum_{j=1}^n N_{i,k}(s)N_{j,k}(t)P_{i,j}$$

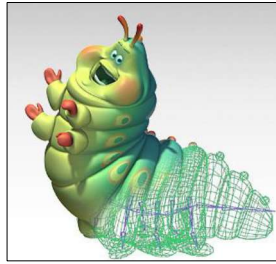

121

## Voronoi diagrams

The *Voronoi diagram*<sup>(2)</sup> of a set of points  $P_i$  divides space into 'cells', where each cell  $C_i$  contains the points in space closer to  $P_i$  than any other  $P_j$ . The *Delaunay triangulation* is the dual of the Voronoi diagram: a graph in which an edge connects every  $P_i$  which share a common edge in the Voronoi diagram.

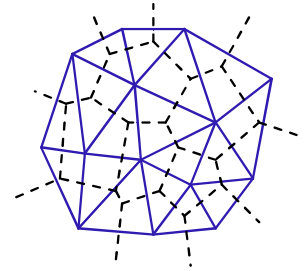

A Voronoi diagram (dotted lines) and its dual Delaunay triangulation (solid).

<sup>(2)</sup> AKA "Voronoi tessellation", "Dirichlet domain", "Thiessen polygons", "plesiohedra", "fundamental areas", "domain of action"...

122

## Voronoi diagrams

Given a set  $S = \{p_1, p_2, \dots, p_n\}$ , the formal definition of a Voronoi cell  $C(S, p_i)$  is  $C(S, p_i) = \{p \in R^d \mid |p - p_i| < |p - p_j|, i \neq j\}$ . The  $p_i$  are called the *generating points* of the diagram.

Where three or more boundary edges meet is a *Voronoi point*. Each Voronoi point is at the center of a circle (or sphere, or hypersphere...) which passes through the associated generating points and which is guaranteed to be empty of all other generating points.

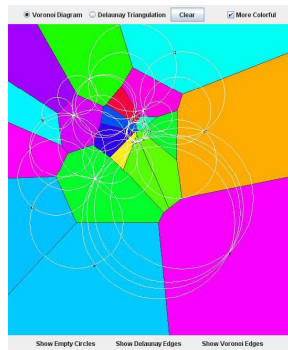

Delaunay triangulation applet by Paul Chew ©1997–2007 <http://www.cs.cornell.edu/home/chew/Delaunay.html>

123

## Delaunay triangulations and *equi-angularity*

The *equiangularity* of any triangulation of a set of points  $S$  is an ascended sorted list of the angles  $(\alpha_1 \dots \alpha_{3n})$  of the triangles.

- A triangulation is said to be *equiangular* if it possesses lexicographically largest equiangularity amongst all possible triangulations of  $S$ .
- The Delaunay triangulation is equiangular.

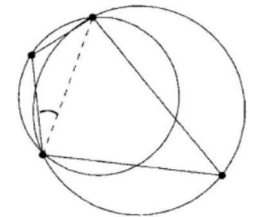

Image from *Handbook of Computational Geometry* (2000) Jörg-Rüdiger Sack and Jorge Urrutia, p. 227

124

## Delaunay triangulations and *empty circles*

Voronoi triangulations have the *empty circle* property: in any Voronoi triangulation of  $S$ , no point of  $S$  will lie inside the circle circumscribing any three points sharing a triangle in the Voronoi diagram.

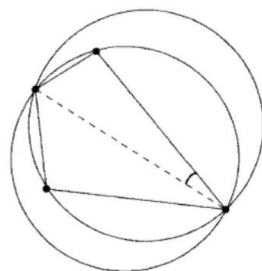

Image from *Handbook of Computational Geometry* (2000) Jörg-Rüdiger Sack and Jorge Urrutia, p. 227

125

## Delaunay triangulations and convex hulls

The border of the Delaunay triangulation of a set of points is always convex.

- This is true in 2D, 3D, 4D...

The Delaunay triangulation of a set of points in  $R^n$  is the planar projection of a convex hull in  $R^{n+1}$ .

- Ex: from 2D ( $P_i = \{x, y\}_i$ ), loft the points upwards, onto a parabola in 3D ( $P'_i = \{x, y, x^2 + y^2\}_i$ ). The resulting polyhedral mesh will still be convex in 3D.

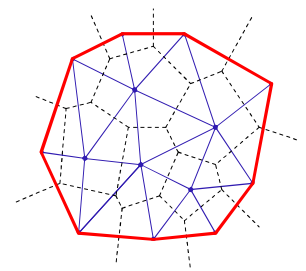

126

## Voronoi diagrams and the medial axis

The *medial axis* of a surface is the set of all points within the surface equidistant to the two or more nearest points on the surface.

- This can be used to extract a skeleton of the surface, for (for example) path-planning solutions, surface deformation, and animation.



[Approximating the Medial Axis from the Voronoi Diagram with a Convergence Guarantee](#)  
Tamal K. Dey, Walter Zhao

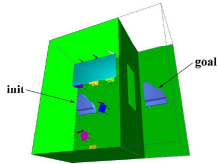

[A Voronoi-Based Hybrid Motion Planner for Rigid Bodies](#)  
M Foskey, M Garber, M Lin, DManocha

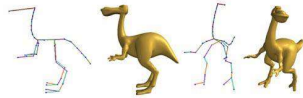

[Shape Deformation using a Skeleton to Drive Simplicial Transformations](#)  
IEEE Transactions on Visualization and Computer Graphics, Vol. 14, No. 3, May/June 2008, Page 694-706  
Hao-Rong Yan, Shi-Min Hu, Ralph R Martin, and Yong-Liang Yang

## Finding the Voronoi diagram

There are four general classes of algorithm for computing the Delaunay triangulation:

- Divide-and-conquer
- Sweep plane
  - Ex: Fortune's algorithm →
- Incremental insertion
- "Flipping": repairing an existing triangulation until it becomes Delaunay

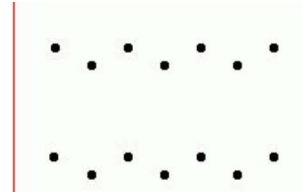

*Fortune's Algorithm* for the plane-sweep construction of the Voronoi diagram (Steve Fortune, 1986.)

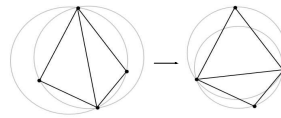

This triangulation fails the circumcircle definition, we flip its inner edge and it becomes Delaunay. (Image from Wikipedia.)

## Fortune's algorithm

- The algorithm maintains a sweep line and a "beach line", a set of parabolas advancing left-to-right from each point. The beach line is the union of these parabolas.
  - The intersection of each pair of parabolas is an edge of the voronoi diagram
  - All data to the left of the beach line is "known"; nothing to the right can change it
  - The beach line is stored in a binary tree
- Maintain a queue of two classes of event: the addition of, or removal of, a parabola
- There are  $O(n)$  such events, so Fortune's algorithm is  $O(n \log n)$



## GPU-accelerated Voronoi Diagrams

Brute force:

- For each pixel to be rendered on the GPU, search all points for the nearest point

Elegant (and 2D only):

- Render each point as a discrete 3D cone in isometric projection, let z-buffering sort it out

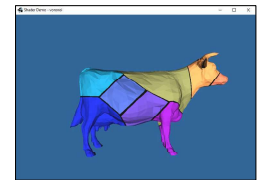
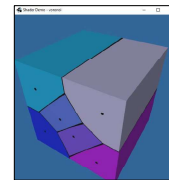

## Voronoi cells in 3D

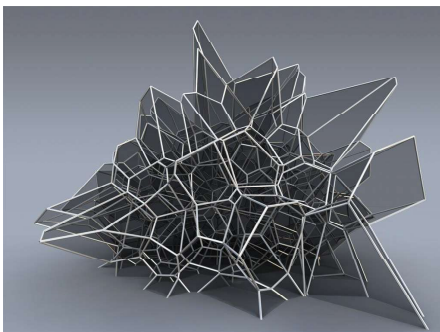

Silvan Oesterle, Michael Krauss

## References

### Splines, continued

- Les Piegl and Wayne Tiller, *The NURBS Book*, Springer (1997)
- Alan Watt, *3D Computer Graphics*, Addison Wesley (2000)
- G. Farin, J. Hoschek, M.-S. Kim, *Handbook of Computer Aided Geometric Design*, North-Holland (2002)

### Voronoi diagrams

- M. de Berg, O. Cheong, M. van Kreveld, M. Overmars, "Computational Geometry: Algorithms and Applications", Springer-Verlag
- <http://www.cs.uu.nl/geobook>
- <http://www.ics.uci.edu/~eppstein/junkyard/nn.html>
- <http://www.iquilezles.org/www/articles/voronoi/voronoi.html>



## Lecture 6

### Subdivision Surfaces

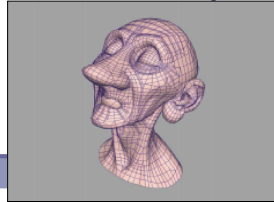

Alex Benton, University of Cambridge – alex@bentonian.com  
Supported in part by Google UK, Ltd

133

## Problems with Bezier (NURBS) patches

- Joining spline patches with  $C_n$  continuity across an edge is challenging.
- What happens to continuity at corners where the number of patches meeting isn't exactly four?
- Animation is tricky: bending and blending are doable, but not easy.

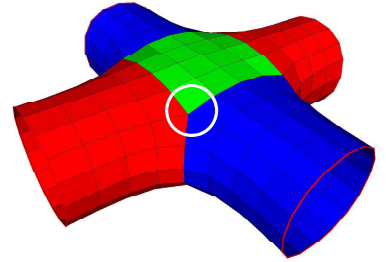

Sadly, the world isn't made up of shapes that can always be made from one smoothly-deformed rectangular surface.

134

## Subdivision surfaces

- Beyond shipbuilding: we want guaranteed continuity, without having to build everything out of rectangular patches.
  - Applications include CAD/CAM, 3D printing, museums and scanning, medicine, movies...
- The solution: *subdivision surfaces*.



Geri's Game, by Pixar (1997)

135

## Subdivision surfaces

- Instead of ticking a parameter  $t$  along a parametric curve (or the parameters  $u, v$  over a parametric grid), subdivision surfaces repeatedly refine from a coarse set of *control points*.
- Each step of refinement adds new faces and vertices.
- The process converges to a smooth *limit surface*.

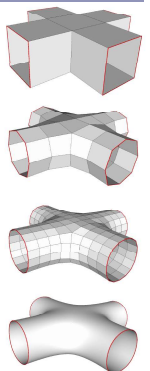

(Catmull-Clark in action)

## Subdivision surfaces – History

- de Rahm described a 2D (curve) subdivision scheme in 1947; rediscovered in 1974 by Chaikin
- Concept extended to 3D (surface) schemes by two separate groups during 1978:
  - Doo and Sabin found a biquadratic surface
  - Catmull and Clark found a bicubic surface
- Subsequent work in the 1980s (Loop, 1987; Dyn [Butterfly subdivision], 1990) led to tools suitable for CAD/CAM and animation

137

## Subdivision surfaces and the movies

- Pixar first demonstrated subdivision surfaces in 1997 with Geri's Game.
  - Up until then they'd done everything in NURBS (Toy Story, A Bug's Life.)
  - From 1999 onwards everything they did was with subdivision surfaces (Toy Story 2, Monsters Inc, Finding Nemo...)
  - Two decades on, it's all heavily customized - creases and edges can be detailed by artists and regions of subdivision can themselves be dynamically subdivided

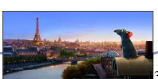
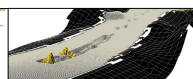
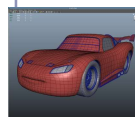

138

## Useful terms

- A scheme which describes a 1D curve (even if that curve is travelling in 3D space, or higher) is called *univariate*, referring to the fact that the limit curve can be approximated by a polynomial in one variable ( $t$ ).
- A scheme which describes a 2D surface is called *bivariate*, the limit surface can be approximated by a  $u,v$  parameterization.
- A scheme which retains and passes through its original control points is called an *interpolating* scheme.
- A scheme which moves away from its original control points, converging to a limit curve or surface nearby, is called an *approximating* scheme.

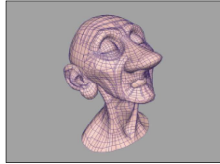

Control surface for Geri's head

139

## How it works

- Example: *Chaikin* curve subdivision (2D)
  - On each edge, insert new control points at  $1/4$  and  $3/4$  between old vertices; delete the old points
  - The *limit curve* is C1 everywhere (despite the poor figure.)

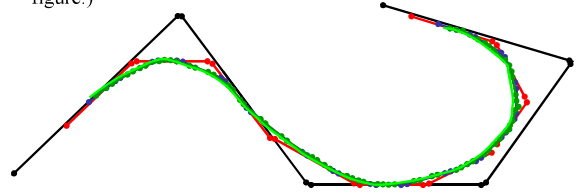

140

## Notation

Chaikin can be written programmatically as:

$$\begin{array}{l}
 P_i^k \\
 | \\
 P_{2i}^{k+1} \\
 | \\
 P_{2i+1}^{k+1} \\
 | \\
 P_{i+1}^k
 \end{array}
 \quad
 \begin{array}{l}
 P_{2i}^{k+1} = (3/4)P_i^k + (1/4)P_{i+1}^k \quad \leftarrow \text{Even} \\
 P_{2i+1}^{k+1} = (1/4)P_i^k + (3/4)P_{i+1}^k \quad \leftarrow \text{Odd}
 \end{array}$$

... where  $k$  is the 'generation'; each generation will have twice as many control points as before.

Notice the different treatment of generating odd and even control points.

Borders (terminal points) are a special case.

141

## Notation

Chaikin can be written in vector notation as:

$$\begin{bmatrix} \vdots \\ P_{2i-2}^{k+1} \\ P_{2i-1}^{k+1} \\ P_{2i}^{k+1} \\ P_{2i+1}^{k+1} \\ P_{2i+2}^{k+1} \\ P_{2i+3}^{k+1} \\ \vdots \end{bmatrix} = \frac{1}{4} \begin{bmatrix} \vdots \\ 0 & 3 & 1 & 0 & 0 & 0 \\ 0 & 1 & 3 & 0 & 0 & 0 \\ 0 & 0 & 3 & 1 & 0 & 0 \\ 0 & 0 & 1 & 3 & 0 & 0 \\ 0 & 0 & 0 & 3 & 1 & 0 \\ 0 & 0 & 0 & 1 & 3 & 0 \\ \vdots & & & & & \vdots \end{bmatrix} \begin{bmatrix} \vdots \\ P_{i-2}^k \\ P_{i-1}^k \\ P_i^k \\ P_{i+1}^k \\ P_{i+2}^k \\ P_{i+3}^k \\ \vdots \end{bmatrix}$$

142

## Notation

- The standard notation compresses the scheme to a *kernel*:
  - $h = (1/4)[\dots, 0, 0, 1, 3, 3, 1, 0, 0, \dots]$
- The kernel interlaces the odd and even rules.
- It also makes matrix analysis possible: eigenanalysis of the matrix form can be used to prove the continuity of the subdivision limit surface.
  - The details of analysis are fascinating, lengthy, and sadly beyond the scope of this course
- The limit curve of Chaikin is a quadratic B-spline!

143

## Reading the kernel

Consider the kernel

$$h = (1/8)[\dots, 0, 0, 1, 4, 6, 4, 1, 0, 0, \dots]$$

You would read this as

$$P_{2i}^{k+1} = (1/8)(P_{i-1}^k + 6P_i^k + P_{i+1}^k)$$

$$P_{2i+1}^{k+1} = (1/8)(4P_i^k + 4P_{i+1}^k)$$

The limit curve is provably C2-continuous.



144



## Making the jump to 3D: Doo-Sabin

Doo-Sabin takes Chaikin to 3D:

$$\begin{aligned}
 P &= (9/16)A + \\
 & (3/16)B + \\
 & (3/16)C + \\
 & (1/16)D
 \end{aligned}$$

This replaces every old vertex with four new vertices.  
The limit surface is biquadratic, C1 continuous everywhere.

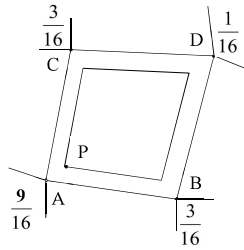

145

## Doo-Sabin in action

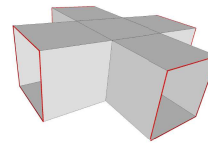

(0) 18 faces

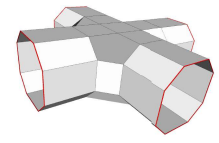

(1) 54 faces

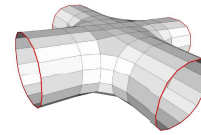

(2) 190 faces

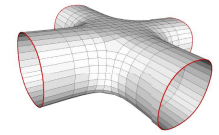

(3) 702 faces

146

## Catmull-Clark

- Catmull-Clark is a bivariate approximating scheme with kernel  $h=(1/8)[1,4,6,4,1]$ .
  - Limit surface is bicubic, C2-continuous.

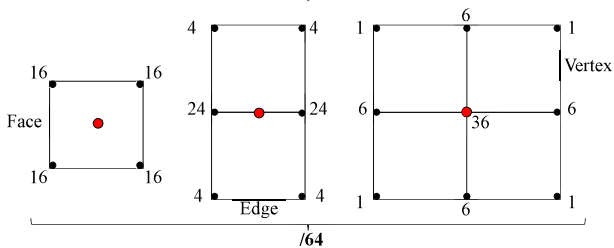

147

## Catmull-Clark

Getting tensor again:

$$\frac{1}{8} \begin{bmatrix} 1 \\ 4 \\ 6 \\ 4 \\ 1 \end{bmatrix} \otimes \frac{1}{8} \begin{bmatrix} 1 \\ 4 \\ 6 \\ 4 \\ 1 \end{bmatrix} = \frac{1}{64} \begin{bmatrix} 1 & 4 & 6 & 4 & 1 \\ 4 & 16 & 24 & 16 & 4 \\ 6 & 24 & 36 & 24 & 6 \\ 4 & 16 & 24 & 16 & 4 \\ 1 & 4 & 6 & 4 & 1 \end{bmatrix}$$

Vertex rule      Face rule      Edge rule

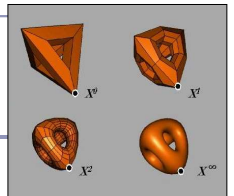

148

## Catmull-Clark in action

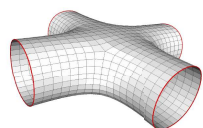
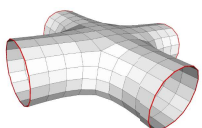
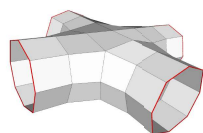
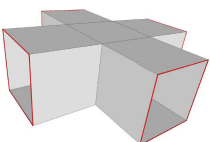

149

## Catmull-Clark vs Doo-Sabin

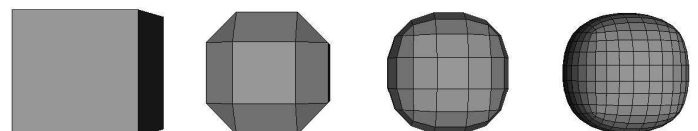

Doo-Sabin

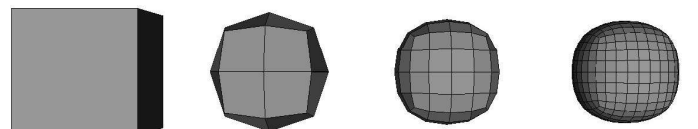

Catmull-Clark

150

## Extraordinary vertices

- Catmull-Clark and Doo-Sabin both operate on quadrilateral meshes.
  - All faces have four boundary edges
  - All vertices have four incident edges
- What happens when the mesh contains extraordinary vertices or faces?
  - For many schemes, adaptive weights exist which can continue to guarantee at least some (non-zero) degree of continuity, but not always the best possible.
- CC replaces extraordinary faces with extraordinary vertices; DS replaces extraordinary vertices with extraordinary faces.

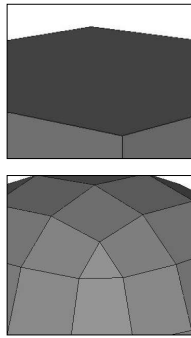

Detail of Doo-Sabin at cube corner

151

## Extraordinary vertices: Catmull-Clark

Catmull-Clark vertex rules generalized for extraordinary vertices:

- Original vertex:  $(4n-7)/4n$
- Immediate neighbors in the one-ring:  $3/2n^2$
- Interleaved neighbors in the one-ring:  $1/4n^2$

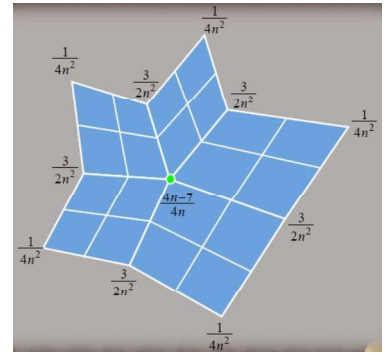
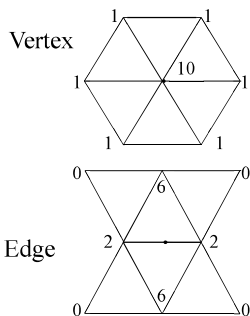

Image source: "Next-Generation Rendering of Subdivision Surfaces", Ignacio Castaño, SIGGRAPH 2008

152

## Schemes for simplicial (triangular) meshes

• Loop scheme:



• Butterfly scheme:

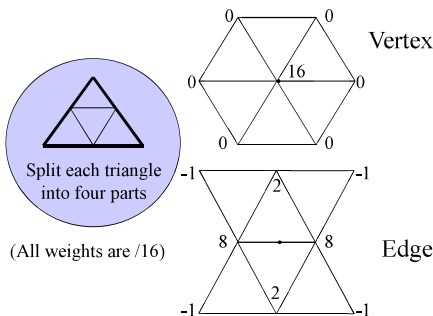

153

## Loop subdivision

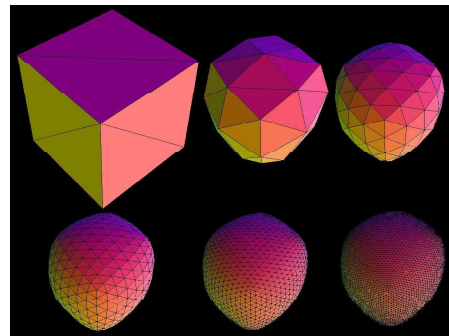

Loop subdivision in action. The asymmetry is due to the choice of face diagonals.  
Image by Matt Fisher, [http://www.its.caltech.edu/~matthewf/Chatter\\_Subdivision.html](http://www.its.caltech.edu/~matthewf/Chatter_Subdivision.html)

154

## Creases

Extensions exist for most schemes to support creases, vertices and edges flagged for partial or hybrid subdivision.

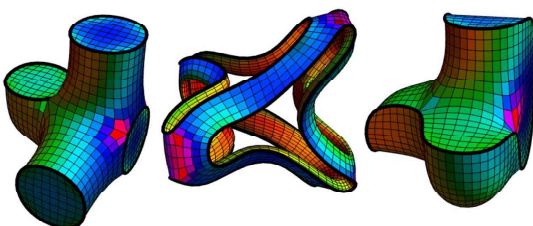

Still from "Volume Enclosed by Subdivision Surfaces with Sharp Creases" by Jan Hakenberg, Ulrich Reif, Scott Schaefer, Joe Warren <http://visra.org/pd/1406.0060v1.pdf>

155

## Splitting a subdivision surface

Many algorithms rely on subdividing a surface and examining the bounding boxes of smaller facets.

- Rendering, ray/surface intersections...

It's not enough just to delete half your control points: the limit surface will change (see right)

- Need to include all control points from the previous generation, which influence the limit surface in this smaller part.

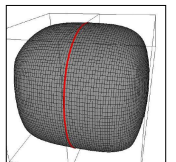
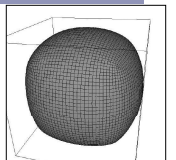

(Top) 5x Catmull-Clark subdivision of a cube  
(Bottom) 5x Catmull-Clark subdivision of two halves of a cube; the limit surfaces are clearly different.

156

## Continuous level of detail

For live applications (e.g. games) can compute *continuous* level of detail, typically as a function of distance:

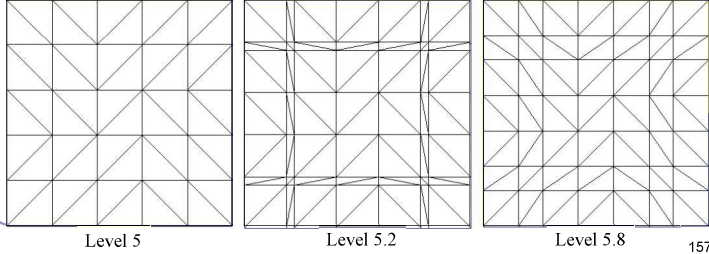

Level 5

Level 5.2

Level 5.8

157

## Bounding boxes and convex hulls for subdivision surfaces

- The limit surface is (the weighted average of (the weighted averages of (the weighted averages of (repeat for eternity...))) the original control points.
- This implies that for any scheme where all weights are positive and sum to one, the limit surface lies entirely within the convex hull of the original control points.
- For schemes with negative weights:
  - Let  $L = \max_i \sum_j |N_j(t)|$  be the greatest sum throughout parameter space of the absolute values of the weights.
  - For a scheme with negative weights,  $L$  will exceed 1.
  - Then the limit surface must lie within the convex hull of the original control points, expanded unilaterally by a ratio of  $(L-1)$ .

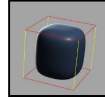

158

## Subdivision Schemes—A partial list

- Approximating
    - Quadrilateral
      - (1/2)[1,2,1]
      - (1/4)[1,3,3,1] (Doo-Sabin)
      - (1/8)[1,4,6,4,1] (Catmull-Clark)
      - Mid-Edge
    - Triangles
      - Loop
  - Interpolating
    - Quadrilateral
      - Kobbelt
    - Triangle
      - Butterfly
      - “ $\sqrt{3}$ ” Subdivision
- Many more exist, some much more complex  
This is a major topic of ongoing research

160

## References

- Catmull, E., and J. Clark. “Recursively Generated B-Spline Surfaces on Arbitrary Topological Meshes.” *Computer Aided Design*, 1978.
- Dyn, N., J. A. Gregory, and D. A. Levin. “Butterfly Subdivision Scheme for Surface Interpolation with Tension Control.” *ACM Transactions on Graphics*. Vol. 9, No. 2 (April 1990): pp. 160–169.
- Halstead, M., M. Kass, and T. DeRose. “Efficient, Fair Interpolation Using Catmull-Clark Surfaces.” *Siggraph '93*, p. 35.
- Zorin, D. “Stationary Subdivision and Multiresolution Surface Representations.” Ph.D. diss., California Institute of Technology, 1997
- Ignacio Castano. “Next-Generation Rendering of Subdivision Surfaces.” *Siggraph '08*, <http://developer.nvidia.com/object/siggraph-2008-Subdiv.html>
- Dennis Zorin’s SIGGRAPH course, “Subdivision for Modeling and Animation”, <http://www.mrl.nyu.edu/publications/subdiv-course2000/>

160

## Lecture 7



Global Illumination

Alex Benton, University of Cambridge – alex@bentonian.com  
Supported in part by Google UK, Ltd.

161

## Improving on the classic lighting model

- Soft shadows are expensive
- Shadows of transparent objects require further coding or hacks
- Lighting off reflective objects follows different shadow rules from normal lighting
- Hard to implement diffuse reflection color bleeding, such as in the Cornell Box—notice how the sides of the inner cubes are shaded red and green.)
- Fundamentally, the ambient term is a hack and the diffuse term is only one step in what should be a recursive, self-reinforcing series.



The Cornell Box is a test for rendering Software, developed at Cornell University in 1984 by Don Greenberg. An actual box is built and photographed; an identical scene is then rendered in software and the two images are compared.

162

## Anisotropic shading

*Anisotropic shading* occurs in nature when light reflects off a surface differently in one direction from another, as a function of the surface itself. The specular component is modified by the direction of the light.



<http://www.blenderguru.com/a-ibos-introduction-to-anisotropic-shading/>

163

## Ambient occlusion

- *Ambient illumination* is a blanket constant that we often add to every illuminated element in a scene, to (inaccurately) model the way that light scatters off all surfaces, illuminating areas not in direct lighting.
- *Ambient occlusion* is the technique of adding/removing ambient light when other objects are nearby and scattered light wouldn't reach the surface.
- Computing ambient occlusion is a form of *global illumination*, in which we compute the lighting of scene elements in the context of the scene as a whole.

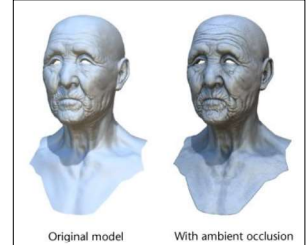

Image from "ZBrush® Character Creation: Advanced Digital Sculpting, Second Edition", by Scott Spencer, 2014

## Ambient occlusion in action



Car photos from John Hable's presentation at GDC 2010, "Uncharted 2: HDR Lighting" ([dlm.isgames.com/archives/165](http://dlm.isgames.com/archives/165))

## Ambient occlusion in action



Car photos from John Hable's presentation at GDC 2010, "Uncharted 2: HDR Lighting" ([dlm.isgames.com/archives/166](http://dlm.isgames.com/archives/166))

## Ambient occlusion in action



Car photos from John Hable's presentation at GDC 2010, "Uncharted 2: HDR Lighting" ([dlm.isgames.com/archives/167](http://dlm.isgames.com/archives/167))

## Ambient occlusion in action



Car photos from John Hable's presentation at GDC 2010, "Uncharted 2: HDR Lighting" ([dlm.isgames.com/archives/168](http://dlm.isgames.com/archives/168))

## Ambient occlusion - Theory

We can treat the background (the sky) as a vast ambient illumination source.

- For each vertex of a surface, compute how much background illumination reaches the vertex by computing how much sky it can 'see'
- Integrate occlusion  $A_p$  over the hemisphere around the normal at the vertex:

$$A_p = \frac{1}{\pi} \int_{\Omega} V_{p,\omega} (\hat{n} \cdot \hat{\omega}) d\omega$$

- $A_p$  occlusion at point  $p$
- $\hat{n}$  normal at point  $p$
- $V_{p,\omega}$  visibility from  $p$  in direction  $\omega$
- $\Omega$  integrate over area (hemisphere)

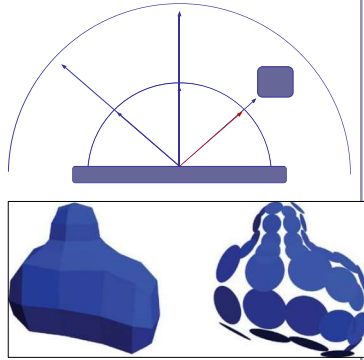

Bottom image credit: "GPU Gems 2", nVidia, 2005. Vertices mapped to illumination disks for hemispheric illumination mapping. 169

## Ambient occlusion - Theory

- This approach is very flexible
- Also very expensive!
- To speed up computation, randomly sample rays cast out from each polygon or vertex (this is a Monte-Carlo method)
- Alternatively, render the scene from the point of view of each vertex and count the background pixels in the render
- Best used to pre-compute per-object "occlusion maps", texture maps of shadow to overlay onto each object
- But pre-computed maps fare poorly on animated models...

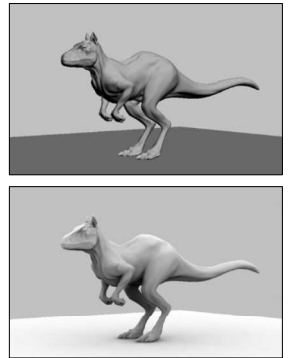

Image credit: "GPU Gems 1", nVidia, 2004. Top: without AO. Bottom: with AO. 170

## Screen Space Ambient Occlusion ("SSAO")

"True ambient occlusion is hard, let's go hacking."

- Approximate ambient occlusion by comparing z-buffer values in screen space!
- Open plane = unoccluded
- Closed 'valley' in depth buffer = shadowed by nearby geometry
- Multi-pass algorithm
- Runs entirely on the GPU

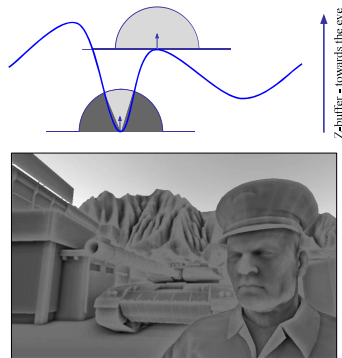

Image: CryEngine 2. M. Mittig, "Finding Next Gen - CryEngine 2.0, Chapter 8", SIGGRAPH 2007 Course 28 171

## Screen Space Ambient Occlusion

1. For each visible point on a surface in the scene (ie., each pixel), take multiple samples (typically between 8 and 32) from nearby and map these samples back to screen space
2. Check if the depth sampled at each neighbor is nearer to, or further from, the scene sample point
3. If the neighbor is nearer than the scene sample point then there is some degree of occlusion
  - a. Care must be taken not to occlude if the nearer neighbor is too much nearer than the scene sample point; this implies a separate object, much closer to the camera
4. Sum retained occlusions, weighting with an occlusion function

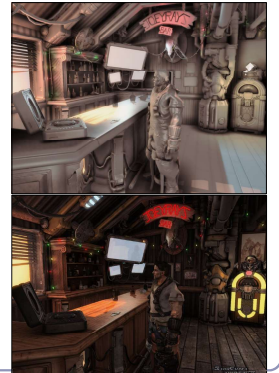
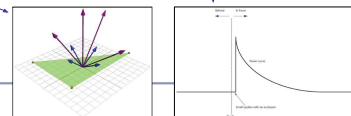

Image: StarCraft II. Advances in Real-Time Rendering in HD, Graphics and Games • Course notes, SIGGRAPH 2008 172

## SSAO example- Uncharted 2



4) Low Pass Filter (significant blurring)

John Hable, GDC 2010, "Uncharted 2: HDR Lighting" (http://www.gamedev.com/artists/0) 173

## Ambient occlusion and Signed Distance Fields

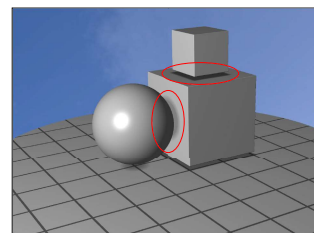

In a nutshell, SSAO tries to estimate occlusion by asking, "how far is it to the nearest neighboring geometry?"  
With signed distance fields, this question is almost trivial to answer.

```
float ambient(vec3 pt, vec3 normal) {
    return abs(getSdf(pt + 0.1 * normal)) / 0.1;
}
```

```
float ambient(vec3 pt, vec3 normal) {
    float a = 1;
    int step = 0;
    for (float t = 0.01; t <= 0.1; ) {
        float d = abs(getSdf(pt + t * normal));
        a = min(a, d / t);
        t += max(d, 0.01);
    }
    return a;
}
```

## Radiosity

- *Radiosity* is an illumination method which simulates the global dispersion and reflection of diffuse light.
  - First developed for describing spectral heat transfer (1950s)
  - Adapted to graphics in the 1980s at Cornell University
- Radiosity is a finite-element approach to global illumination: it breaks the scene into many small elements ('*patches*') and calculates the energy transfer between them.

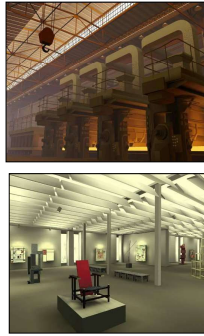

Images from Cornell University's graphics group  
<http://www.electra.cornell.edu/online/research/> 175

## Radiosity—algorithm

- Surfaces in the scene are divided into *patches*, small subsections of each polygon or object.
- For every pair of patches A, B, compute a *view factor* (also called a *form factor*) describing how much energy from patch A reaches patch B.
  - The further apart two patches are in space or orientation, the less light they shed on each other, giving lower view factors.
- Calculate the lighting of all directly-lit patches.
- Bounce the light from all lit patches to all those they light, carrying more light to patches with higher relative view factors. Repeating this step will distribute the total light across the scene, producing a global diffuse illumination model.

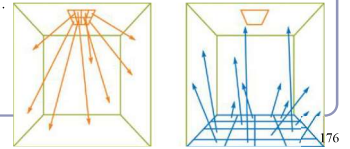

## Radiosity—mathematical support

The 'radiosity' of a single patch is the amount of energy leaving the patch per discrete time interval. This energy is the total light being emitted directly from the patch combined with the total light being reflected by the patch:

$$B_i = E_i + R_i \sum_{j=1}^n B_j F_{ij}$$

This forms a system of linear equations, where...

- $B_i$  is the radiosity of patch  $i$ ,
- $B_j$  is the radiosity of each of the other patches ( $j \neq i$ )
- $E_i$  is the emitted energy of the patch
- $R_i$  is the reflectivity of the patch
- $F_{ij}$  is the view factor of energy from patch  $i$  to patch  $j$ .

177

## Radiosity—form factors

- Finding form factors can be done procedurally or dynamically
  - Can subdivide every surface into small patches of similar size
  - Can dynamically subdivide wherever the 1<sup>st</sup> derivative of calculated intensity rises above some threshold.
- Computing cost for a general radiosity solution goes up as the square of the number of patches, so try to keep patches down.
  - Subdividing a large flat white wall could be a waste.
- Patches should ideally closely align with lines of shadow.

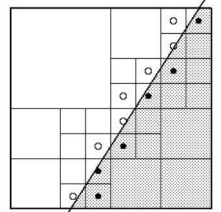

178

## Radiosity—implementation

- (A) Simple patch triangulation
- (B) Adaptive patch generation: the floor and walls of the room are dynamically subdivided to produce more patches where shadow detail is higher.

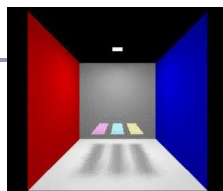

Images from "Automatic generation of node spacing function", IBM (1998)  
<http://www.td.ibm.com/projects/meshing/nsp/nspE.htm>

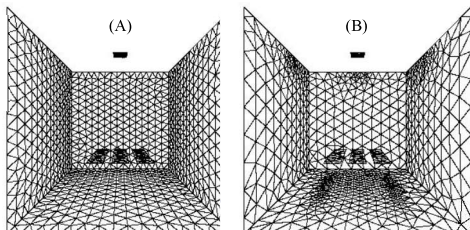

179

## Radiosity—view factors

One equation for the view factor between patches  $i, j$  is:

$$F_{ij} = \frac{\cos \theta_i \cos \theta_j}{\pi r^2} V(i, j)$$

...where  $\theta$  is the angle between the normal of patch  $i$  and the line to patch  $j$ ,  $r$  is the distance and  $V(i, j)$  is the visibility from  $i$  to  $j$  (0 for occluded, 1 for clear line of sight.)

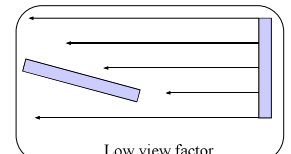
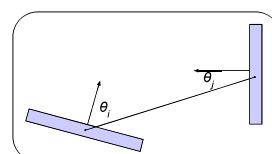
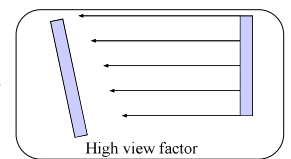

180

## Radiosity—calculating visibility

- Calculating  $V(i,j)$  can be slow.
- One method is the *hemicube*, in which each form factor is encased in a half-cube. The scene is then 'rendered' from the point of view of the patch, through the walls of the hemicube;  $V(i,j)$  is computed for each patch based on which patches it can see (and at what percentage) in this hemicube.
- A purer method, but more computationally expensive, uses hemispheres.

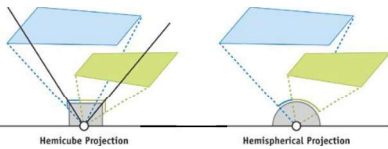

Note: This method can be accelerated using modern graphics hardware to render the scene. The scene is 'rendered' with flat lighting, setting the 'color' of each object to be a pointer to the object in memory.

181

## Radiosity gallery

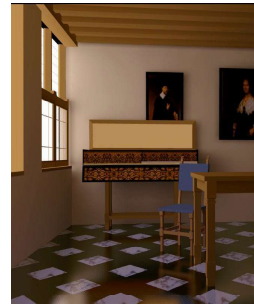

Image from *A Two Pass Solution to the Rendering Equation: a Synthesis of Ray Tracing and Radiosity Methods*, John R. Wallace, Michael P. Cohen and Donald P. Greenberg (Cornell University, 1987)



Image from *GPU Gems II*, uVidia



Teapot (wikipedia)

182

## Shadows, refraction and caustics

- Problem: shadow ray strikes transparent, refractive object.
  - Refracted shadow ray will now miss the light.
  - This destroys the validity of the boolean shadow test.
- Problem: light passing through a refractive object will sometimes form *caustics* (right), artifacts where the envelope of a collection of rays falling on the surface is bright enough to be visible.



This is a photo of a real pepper-shaker. Note the caustics to the left of the shaker, in and outside of its shadow.  
Photo credit: Jan Zankowski

183

## Shadows, refraction and caustics

- Solutions for shadows of transparent objects:
  - Backwards ray tracing (Arvo)
    - Very computationally heavy
    - Improved by stencil mapping (Shenya et al)
  - Shadow attenuation (Pierce)
    - Low refraction, no caustics
- More general solution:
  - Photon mapping (Jensen)→



Image from <http://graphics.ucsd.edu/~henrik/>  
Generated with photon mapping

184

## Photon mapping

*Photon mapping* is the process of emitting photons into a scene and tracing their paths probabilistically to build a *photon map*, a data structure which describes the illumination of the scene independently of its geometry.

This data is then combined with ray tracing to compute the global illumination of the scene.

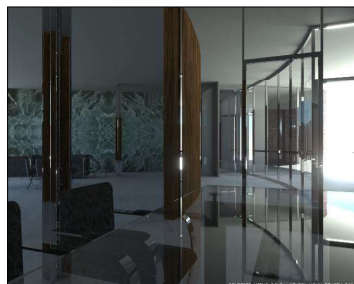

Image by Henrik Jensen (2000)

185

## Photon mapping—algorithm (1/2)

Photon mapping is a two-pass algorithm:

1. Photon scattering
  - A. Photons are fired from each light source, scattered in randomly-chosen directions. The number of photons per light is a function of its surface area and brightness.
  - B. Photons fire through the scene (re-use that raytracer, folks.) Where they strike a surface they are either absorbed, reflected or refracted.
  - C. Wherever energy is absorbed, cache the location, direction and energy of the photon in the *photon map*. The photon map data structure must support fast insertion and fast nearest-neighbor lookup; a *kd-tree*<sup>1</sup> is often used.

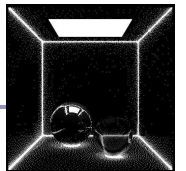

Image by Zack Waters

186

## Photon mapping—algorithm (2/2)

Photon mapping is a two-pass algorithm:

### 2. Rendering

- Ray trace the scene from the point of view of the camera.
- For each first contact point  $P$  use the ray tracer for specular but compute diffuse from the photon map and do away with ambient completely.
- Compute radiant illumination by summing the contribution along the eye ray of all photons within a sphere of radius  $r$  of  $P$ .
- Caustics can be calculated directly here from the photon map. For speed, the caustic map is usually distinct from the radiance map.

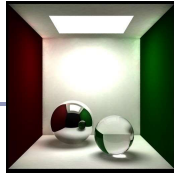

Image by Zack Waters

187

## Photon mapping is probabilistic

This method is a great example of *Monte Carlo integration*, in which a difficult integral (the lighting equation) is simulated by randomly sampling values from within the integral's domain until enough samples average out to about the right answer.

- This means that you're going to be firing *millions* of photons. Your data structure is going to have to be very space-efficient.

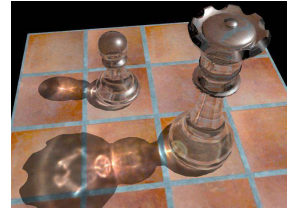

[http://www.okino.com/conv/imp\\_it.htm](http://www.okino.com/conv/imp_it.htm)

188

## Photon mapping is probabilistic

- Initial photon direction is random. Constrained by light shape, but random.
- What exactly happens each time a photon hits a solid also has a random component:
  - Based on the diffuse reflectance, specular reflectance and transparency of the surface, compute probabilities  $p_d$ ,  $p_s$  and  $p_t$ , where  $(p_d + p_s + p_t) \leq 1$ . This gives a probability map:

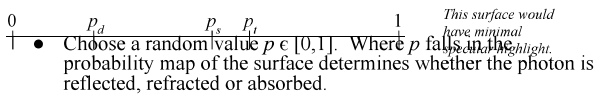

189

## Photon mapping gallery

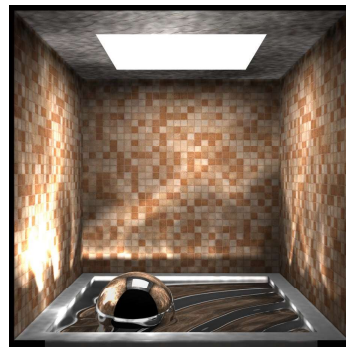

[http://web.cs.wpi.edu/~emmanuel/courses/cs563/writesups/zackw/photom\\_mapping/PhotonMapping.html](http://web.cs.wpi.edu/~emmanuel/courses/cs563/writesups/zackw/photom_mapping/PhotonMapping.html)



<http://graphics.ucsd.edu/~henrik/images/global.html>



<http://www.pbrt.org/gallery.php>

190

## References

Shirley and Marschner, "Fundamentals of Computer Graphics", Chapter 24 (2009)

### Anisotropic surface

- A. Watt, 3D Computer Graphics - Chapter 7: Simulating light-object interaction: local reflection models
- Eurographics 2016 tutorial - D. Guarnera, G. C. Guarnera, A. Ghosh, C. Denk, and M. Gleronross - BRDF Representation and Acquisition

### Ambient occlusion and SSAO

- "GPU Gems 2", nVidia, 2005. Vertices mapped to illumination. [http://http.developer.nvidia.com/GPUGems2/gpugems2\\_chapter14.html](http://http.developer.nvidia.com/GPUGems2/gpugems2_chapter14.html)
- Mitting, M. 2007. *Finding Next Gen - CryEngine 2.0*, Chapter 8, SIGGRAPH 2007 Course 28 - Advanced Real-Time Rendering in 3D Graphics and Games <http://developer.amd.com/worldpress/media/2012/10/Chapter8-Mitting-Finding-NextGen-CryEngine2.pdf>
- John Hable's presentation at GDC 2010, "Uncharted 2: HDR Lighting" ([filmicgames.com/archives/6](http://filmicgames.com/archives/6))

### Radiosity

- [http://http.developer.nvidia.com/GPUGems2/gpugems2\\_chapter39.html](http://http.developer.nvidia.com/GPUGems2/gpugems2_chapter39.html)
- <http://www.graphics.cornell.edu/online/research/>
- Wallace, J. R., K. A. Elmquist, and E. A. Haines. 1989. "A Ray Tracing Algorithm for Progressive Radiosity." In Computer Graphics (Proceedings of SIGGRAPH 89) 23(4), pp. 315-324.
- Buss. "3-D Computer Graphics: A Mathematical Introduction with OpenGL." (Chapter XI), Cambridge University Press (2003)

### Photon mapping

- Henrik Jenson, "Global Illumination using Photon Maps": <http://graphics.ucsd.edu/~henrik/>
- Zack Waters, "Photon Mapping": [http://web.cs.wpi.edu/~emmanuel/courses/cs563/writesups/zackw/photom\\_mapping/PhotonMapping.html](http://web.cs.wpi.edu/~emmanuel/courses/cs563/writesups/zackw/photom_mapping/PhotonMapping.html)

191

## Lecture 8 Virtual Reality

*Immersion and Presence  
in digital realities*



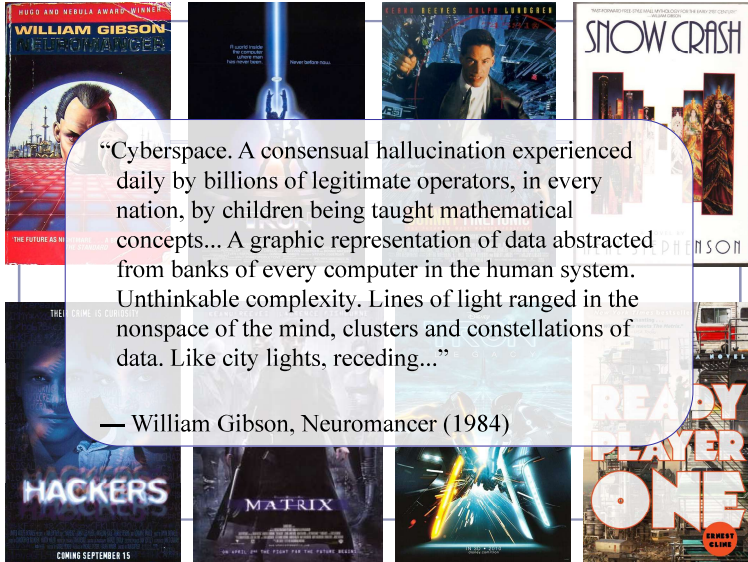

“Cyberspace. A consensual hallucination experienced daily by billions of legitimate operators, in every nation, by children being taught mathematical concepts... A graphic representation of data abstracted from banks of every computer in the human system. Unthinkable complexity. Lines of light ranged in the nonspace of the mind, clusters and constellations of data. Like city lights, receding...”

— William Gibson, Neuromancer (1984)

*What is... the Matrix?*

## What is Virtual Reality?

**Immersion** is the art and technology of surrounding the user with a virtual context, such that there's world above, below, and all around them.

**Presence** is the visceral reaction to a convincing immersion experience. It's when immersion is so good that the body reacts instinctively to the virtual world as though it's the real one.

When you turn your head to look up at the attacking enemy bombers, that's immersion; when you can't stop yourself from ducking as they roar by overhead, that's presence.



Top: HTC Vive (Image credit: Business Insider)  
Middle: The Matrix (1999)  
Bottom: Google Daydream View (2016)

## The “Sword of Damocles” (1968)

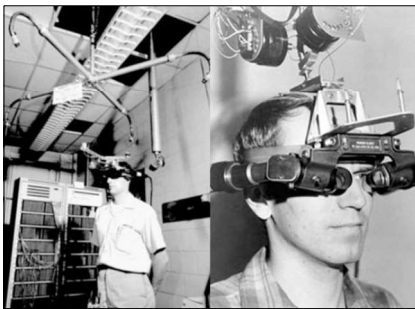

In 1968, Harvard Professor Ivan Sutherland, working with his student Bob Sproull, invented the world's first *head-mounted display*, or *HMD*.

“The right way to think about computer graphics is that the screen is a window through which one looks into a virtual world. And the challenge is to make the world look real, sound real, feel real and interact realistically.”  
-Ivan Sutherland (1965)

## Distance and Vision

Our eyes and brain compute *depth cues* from many different signals:

- **Binocular vision (“stereopsis”)**  
The brain merges two images into one with depth
  - Ocular convergence
  - Shadow stereopsis
- **Perspective**  
Distant things are smaller
- **Parallax motion and occlusion**  
Things moving relative to each other, or in front of each other, convey depth
- **Texture, lighting and shading**  
We see less detail far away; shade shows shape; distant objects are fainter
- **Relative size and position and connection to the ground**  
If we know an object's size we can derive distance, or the reverse; if an object is grounded, perspective on the ground anchors the object's distance



Image: Pere Borrell del Caso's Escapando la Critica ("Escaping Criticism") (1874)

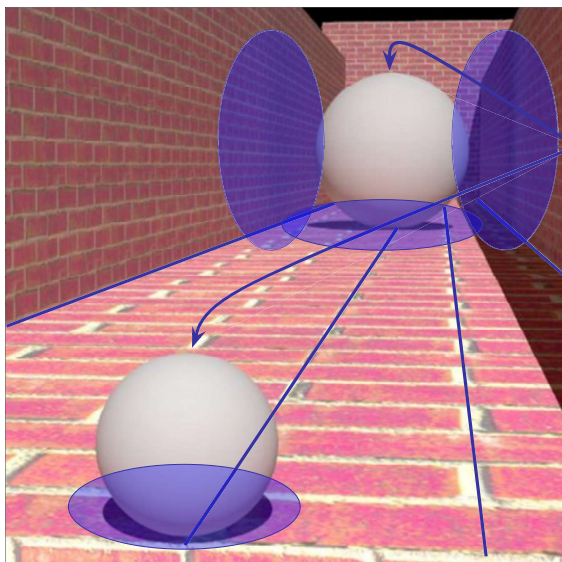

- Perspective
- Occlusion
- Shadows
- Ambient shadows

Image credit: Scott Murray  
Murray, Boyaci, Kersten, The representation of perceived angular size in human primary visual cortex. Nature Neuroscience (2006)

## Binocular display

Today's VR headsets work by presenting similar, but different, views to each eye

Each eye sees an image of the virtual scene from that eye's point of view in VR

This can be accomplished by rendering two views to one screen (Playstation VR, Google Daydream) or two dedicated displays (Oculus Rift, HTC Vive)

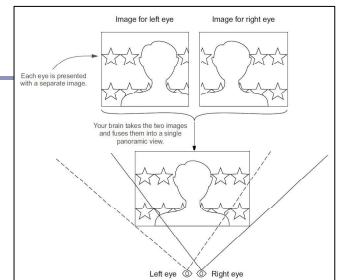

Top: Davis, Bryla, Benton, Oculus Rift in Action (2014)  
Bottom: Oculus DK1 demo scene "Tuscanny"

## Teardown of an Oculus Rift CV1



Teardown of an Oculus Rift CV1 showing details of lenses and displays  
<https://www.ifixit.com/Teardown/Oculus+Rift+CV1+Teardown/90612>

199

## Accounting for lens effects

Lenses bend light: the lenses in the VR headset warp the image on the screen, creating a *pincushion distortion*.

This is countered by first introducing a *barrel distortion* in the GPU shader used to render the image.

The barrel-distorted image stretches back to full size when it's seen through the headset lenses.

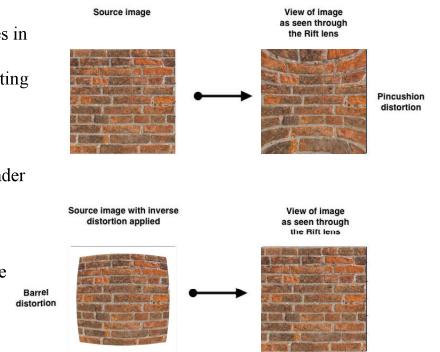
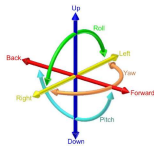

Image credit: Davis, Bryla, Benton, Oculus Rift in Action (2014)

200

## Sensors

Accelerometer and electromagnetic sensors in the headset track the user's *orientation* and *acceleration*. VR software converts these values to a basis which transforms the scene.



Ex: [WebVR API](#):

```
interface VRPose {
  readonly attribute Float32Array? position;
  readonly attribute Float32Array? linearVelocity;
  readonly attribute Float32Array? linearAcceleration;

  readonly attribute Float32Array? orientation;
  readonly attribute Float32Array? angularVelocity;
  readonly attribute Float32Array? angularAcceleration;
};
```

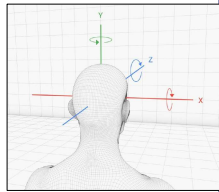

Top: 6DoF (6 degrees of freedom) - Wikipedia  
 Bottom: Roll (Z), Pitch (X) and Yaw (Y) - Google Design

201

## Sensor fusion

**Problem:** Even the best accelerometer can't detect all motion. Over a few seconds, position will drift.

**Solution:** Advanced headsets also track position with separate hardware on the user's desk or walls.

- Oculus Rift: "Constellation", a desk-based IR camera, tracks a pattern of IR LEDs on the headset
- HTC Vive: "base station" units track user in room
- Playstation VR: LEDs captured by PS camera



The goal is to respond in a handful of milliseconds to any change in the user's position or orientation, to preserve presence.



Top: Constellation through an IR-enabled camera (image credit: [ifixit.com](#))  
 Bottom: HTC Vive room setup showing two base stations (image credit: HTC)

202

## Sensors - how fast is fast?

- To preserve presence, the rendered image must respond to changes in head pose faster than the user can perceive
- That's believed to be about 20ms, so no HMD can have a framerate below 50hz
- Most headset display hardware has a higher framerate
  - The Rift CV1 is locked at 90hz
  - Rift software **must** exceed that framerate
  - Failure to do so causes "judder" as frames are lost
  - Judder leads to nausea, nausea leads to hate, hate leads to the dark side

203

## Dealing with latency: sensor prediction

A key immersion improvement is to *predict the future basis*.

This allows software to optimize rendering.

- At time  $t$ , head pos =  $X$ , head velocity =  $V$ , head acceleration =  $A$
- Human heads do not accelerate very fast
- Rendering a single frame takes  $dt$  milliseconds
- At  $t + dt$ , we can predict pos =  $X + Vdt + \frac{1}{2} Adt^2$
- By starting to render the world from the user's predicted head position, when rendering is complete, it aligns with where their head is by then (hopefully).

Ex: The WebVR API returns predicted pose by default

204

## Dealing with latency: ‘timewarp’

Another technique to deal with lost frames is *asynchronous timewarp*.

- Headset pose is fetched immediately before frame display and is used to shift the frame on the display to compensate for ill-predicted head motion

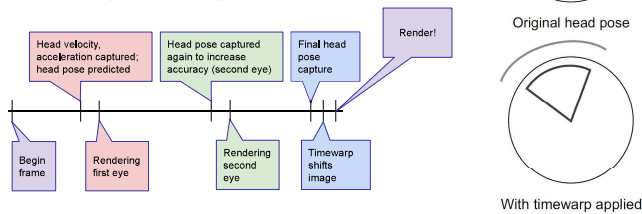

Image credit: Davis, Bryla, Benton, *Oculus Rift in Action* (2014)

205

## Developing for VR

Dedicated SDKs

- [HTC Vive](#)
- [Oculus Rift SDK](#)
  - C++
  - Bindings for Python, Java
- [Google Daydream SDK](#)
  - Android, iOS and Unity
- [Playstation VR](#)
  - Playstation dev kit

General-purpose SDKs

- WebGL - three.js
- [WebVR API](#)

Higher-level game development

- [Unity VR](#)



206

## “Sim sickness”

**The Problem:**

- Your body says, “Ah, we’re sitting still.”
- Your eyes say, “No, we’re moving! It’s exciting!”
- Your body says, “Woah, my inputs disagree! I must have eaten some bad mushrooms. Better get rid of them!”
- Antisocial behavior ensues

The causes of *simulation sickness* (like motion sickness, but in reverse) are many. Severity varies between individuals; underlying causes are poorly understood.

207

## Reducing sim sickness

The cardinal rule of VR:

**The user is in control of the camera.**

- Never** take head-tracking control away from the user
- Head-tracking **must match the user’s motion**
- Avoid moving the user** without direct interaction
- If you must move the user, do so in a way that **doesn’t break presence**

208

## How can you mitigate sim sickness?

Design your UI to reduce illness

- Never mess with the field of view
- Don’t use head bob
- Don’t knock the user around
- Offer multiple forms of camera control
  - Look direction
  - Mouse + keyboard
  - Gamepad
- Try to match in-world character height and *IPD* (*inter-pupillary distance*) to that of the user
- Where possible, give the user a stable in-world reference frame that moves with them, like a vehicle or cockpit

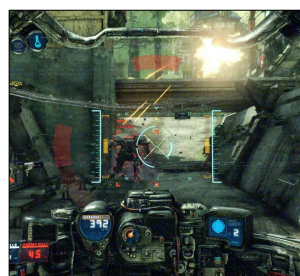

Hawken, by Meteor Entertainment (2014)

209

## Further ways to reduce sim sickness

Design your VR world to reduce illness

- Limit sidestepping, backstepping, turning; never force the user to spin
- If on foot, move at real-world speeds (1.4m/s walk, 3m/s run)
- Don’t use stairs, use ramps
- Design to scale—IPD and character height should match world scale
- Keep the horizon line consistent, static and constant
- Avoid very large moving objects which take up most of the field of view
- Use darker textures
- Avoid flickering, flashing, or high color contrasts
- Don’t put content where they have to roll their eyes to see it
- If possible, build breaks into your VR experience
- If possible, give the user an avatar; if possible, the avatar body should react to user motion, to give an illusion of proprioception

210

## Classic user interfaces in 3D

Many classic UI paradigms *will not work* if you recreate them in VR

- UI locked to sides or corners of the screen will be distorted by lenses and harder to see
- Side and corner positions force the user to roll their eyes
- Floating 3D dialogs create a virtual plane within a virtual world, breaking presence
- Modal dialogs 'pause' the world
- Small text is much harder to read in VR



Top: EVE Online (2003)  
Bottom: Team Fortress (2007)

211

## In-world UIs are evolving

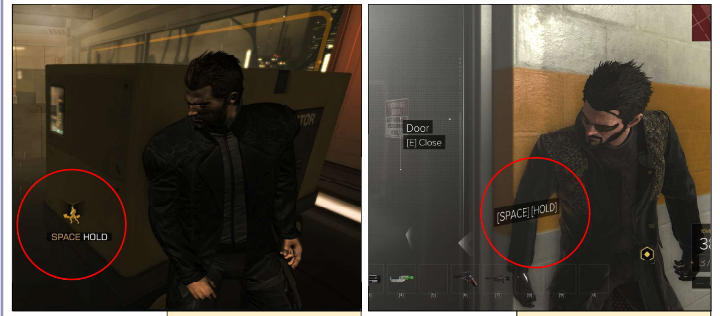

Deus Ex: Human Revolution (2011)

Deus Ex: Mankind Divided (2016)

Increasingly, UI elements are being integrated into the virtual world

212

## The best virtual UI is in-world UI



Top left: Call of Duty: Black Ops (2010)  
Bottom left: Crysis 3 (2013)

Top right: Halo 4 (2012)  
Bottom right: Batman: Arkham Knight (2015)

213

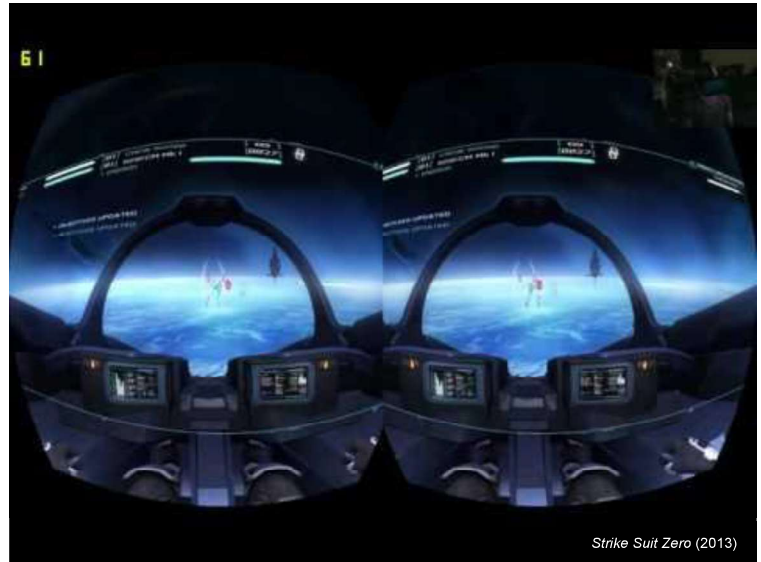

Strike Suit Zero (2013)



Elite: Dangerous (2014)

## Storytelling in games

The visual language of games is often the language of movies

- Cutscenes
- Angle / reverse-angle conversations
- Voiceover narration
- Pans
- Dissolves
- Zooms...



Call of Duty: Modern Warfare 3 (2012)  
The player's helicopter has been shot down; they emerge into gameplay, transitioning smoothly from passive to active.

In VR, storytelling by moving the camera will not work well because the user *is* the camera.

"It's a new communications medium. What is necessary is to develop a grammar and syntax. It's like film. When film was invented, no one knew how to use it. But gradually, a visual grammar was developed. Filmmakers began to understand how the grammar was used to communicate certain things. We have to do the same thing with this."  
Neal Stephenson, *Interface*, 1994

216

## Drawing the user's attention

When presenting dramatic content in VR, you risk the user looking away at a key moment.

- Use audio cues, movement or changing lighting or color to draw focus
- Use other characters in the scene; when they all turn to look at something, the player will too
- Design the scene to direct the eye
- Remember that in VR, you know when key content is in the viewing frustum



The Emperor's New Groove (2000)

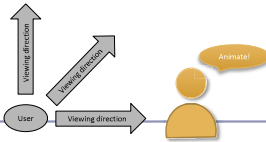

217

## Advice for a good UI

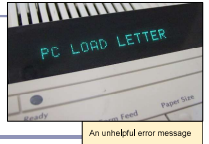

An unhelpful error message

**Always display relevant state**—Primary application state should be visible to the user. For an FPS shoot'em-up, this means showing variables like ammo count and health. Combine audio and video for key cues such as player injury.

**Use familiar context and imagery**—Don't make your users learn specialized terms so they can use your app. If you're writing a surgery interface for medical training, don't force medical students to learn about virtual cameras and FOVs.

**Support undo/redo**—Don't penalize your users for clicking the wrong thing. Make undoing recent actions a primary user interface mode whenever feasible.

**Design to prevent error**—If you want users to enter a value between 1 and 10 in a box, don't ask them to type; they could type 42. Give them a slider instead.

**Build shortcuts for expert users**—The feeling that you're becoming an expert in a system often comes from learning its shortcuts. Make sure that you offer combos and shortcuts that your users can learn—but don't require them.

**Don't require expert understanding**—Visually indicate when an action can be performed, and provide useful data if the action will need context. If a jet fighter pilot can drop a bomb, then somewhere on the UI should be a little indicator of the number of bombs remaining. That tells players that bombs are an option and how many they've got. If it takes a key press to drop the bomb, show that key on the UI.

**Keep it simple**—Don't overwhelm your users with useless information; don't compete with yourself for space on the screen. Always keep your UI simple. "If you can't explain it to a six-year-old, you don't understand it yourself" (attributed to Albert Einstein).

**Make error messages meaningful**—Don't force users to look up arcane error codes. If something goes wrong, take the time to clearly say what, and more important, what the user should do about it.

Abridged from *Usability Engineering* by Jakob Nielsen (Morgan Kaufmann, 1993)

218

## Gestural interfaces

Hollywood has been training us for a while now to expect *gestural user interfaces*.

A gestural interface uses predetermined intuitive hand and body gestures to control virtual representations of material data.

Many hand position capture devices are in development (ex: Leap Motion)

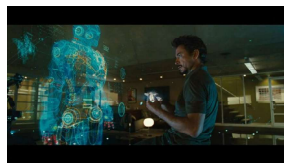

219

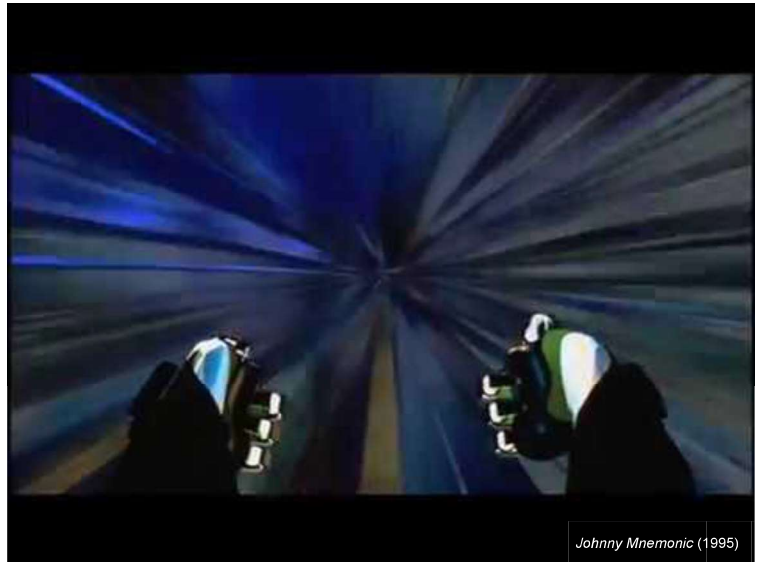

Johnny Mnemonic (1995)



Marvel's Agents of S.H.I.E.L.D. (2013) S01 E13

## References

### Developing in VR

- *Fundamentals of Computer Graphics*, by P. Shirley, M. Ashikhmin, and S. Marschner (A. K. Peters/CRC Press, 2009)
- *Computer Graphics: Principles and Practice*, by J. D. Foley, A. van Dam, S. K. Fagan, and J. F. Hughes (Addison-Wesley Professional, 2013)
- *Oculus Rift in Action*, by Davis, Bryla and Benton (2014)
- *Oculus Best Practices Guide* - [developer.oculus.com/documentation](https://developer.oculus.com/documentation)

### Motion sickness/simulator sickness

- *Textbook of Maritime Medicine*, by the Norwegian Centre for Maritime Medicine (2013). See chapter 20, "Motion Sickness" ([textbook.ncbi.nlm.nih.gov](https://www.ncbi.nlm.nih.gov/pmc/articles/PMC4000000/))
- *Validating an Efficient Method to Quantify Motion Sickness*, by B. Koshvazari and H. Hecht (2011). *Human Factors: The Journal of the Human Factors and Ergonomics Society* 53:4, 411-426.
- *Simulator Sickness Questionnaire*, by R. S. Kennedy, N. E. Lane, K. S. Berbaum, and M. G. Lichtenhal (1993). *The International Journal of Aviation Psychology* 3(3), 205-209.
- *Motion Sickness Susceptibility Questionnaire Revised and Its Relationship to Other Forms of Sickness*, by J. F. Golding (1998). *Brain Research Bulletin*, 47(5): 507-16.

### UI design for VR

- 3D User Interfaces: New Directions and Perspectives, by D. A. Bowman, S. Coquillart, B. Froehlich, M. Hirose, and W. Stuerzlinger. (2008). *IEEE Computer Graphics and Applications* 28(5): 26-36.
- Design and Evaluation of Mouse Cursors in a Stereoscopic Desktop Environment, by L. Schmalz and E. Eisenmann (2014). *3D User Interfaces (3DUI), 2014 IEEE Symposium* (pp. 67-70). IEEE. Recorded talk is available at [vimeo.com/51483071](https://www.youtube.com/watch?v=Uj00714).
- Developing Virtual Reality Games and Experiences—[www.youtube.com/watch?v=Uj00714](https://www.youtube.com/watch?v=Uj00714). Presented at GDC 2014.
- Ergonomic Object Manipulation in Virtual Environments: Empirical Evaluation of Interaction Techniques, by I. Poupyrev, S. Weghorst, M. Billinghurst, and T. Lohkawa (1998). *Computer Graphics Forum*, 17(3): 41-52.
- Kinect Hand Detection, by G. Gallagher—[www.youtube.com/watch?v=Uj00714](https://www.youtube.com/watch?v=Uj00714).
- *Make It Sit: Interaction Design Lessons from Science Fiction*, by S. Shneiderman and C. Noveck (Rosenfeld Media, 2012).
- Lessons learned porting *Team Fortress 2* to virtual reality—<https://www.youtube.com/watch?v=Uj00714>.
- Pointing at 3D Target Projections with One-Eyed and Stereo Cursors, by R. J. Tauber and W. Stuerzlinger (2013). *ACM Conference on Human Factors in Computing Systems*: 150-68.
- Pointing to the Future of UI, by J. Underkofler (2010). Talk given at TED [www.ted.com/talks/john\\_underkofler\\_3d\\_ui\\_data\\_with\\_a\\_gesture](https://www.ted.com/talks/john_underkofler_3d_ui_data_with_a_gesture).
- Selection Using a One-Eyed Cursor in a Fish Tank VR Environment, by C. Ware and K. Lowther (1997). *ACM Transactions on Computer-Human Interaction Journal*, 4(4): 309-42.
- *Usability Engineering*, by J. Nielsen (Morgan Kaufmann, 1993).

222